

DAIHATSU

CHARADE

Chassis

SECTION 6

REAR AXLE & SUSPENSION

6

REAR AXLE	6- 2	SUSPENSION ARM	6-18
SECTIONAL VIEW	6- 2	COMPONENTS	6-18
COMPONENTS	6- 3	REMOVAL	6-18
REMOVAL	6- 4	INSPECTION	6-20
INSPECTION	6- 7	INSTALLATION	6-20
INSTALLATION	6- 8	STRUT ROD	6-22
REAR SUSPENSION	6-11	REMOVAL	6-22
SECTIONAL VIEW	6-11	INSPECTION	6-22
REAR SHOCK ABSORBER	6-11	INSTALLATION	6-22
COMPONENTS	6-11	STABILIZER BAR	6-23
REMOVAL	6-12	COMPONENTS	6-23
DISASSEMBLY	6-13	REMOVAL	6-23
INSPECTION	6-14	INSPECTION	6-24
ASSEMBLY	6-15	INSTALLATION	6-25
INSTALLATION	6-16		

WR-06001

REAR AXLE & SUSPENSION

REAR AXLE SECTIONAL VIEW

Drum Brake

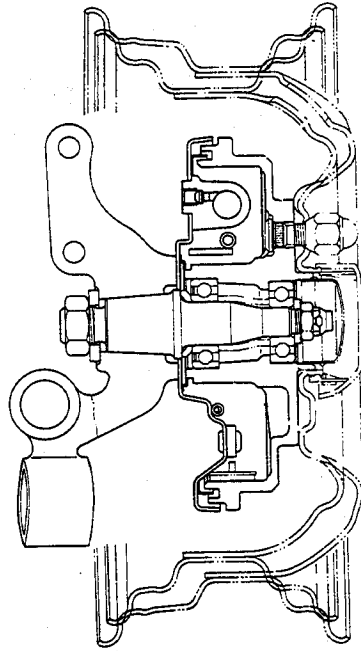

Disc Brake

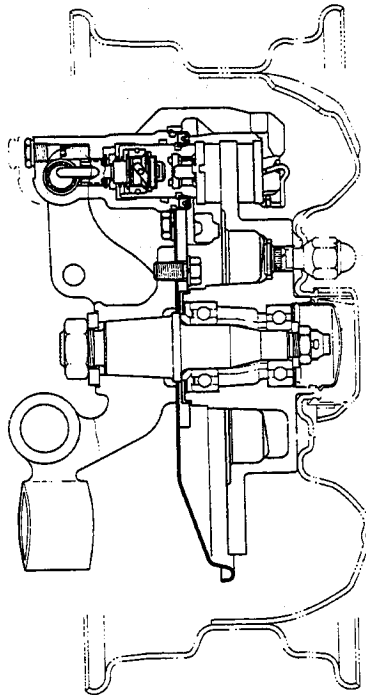
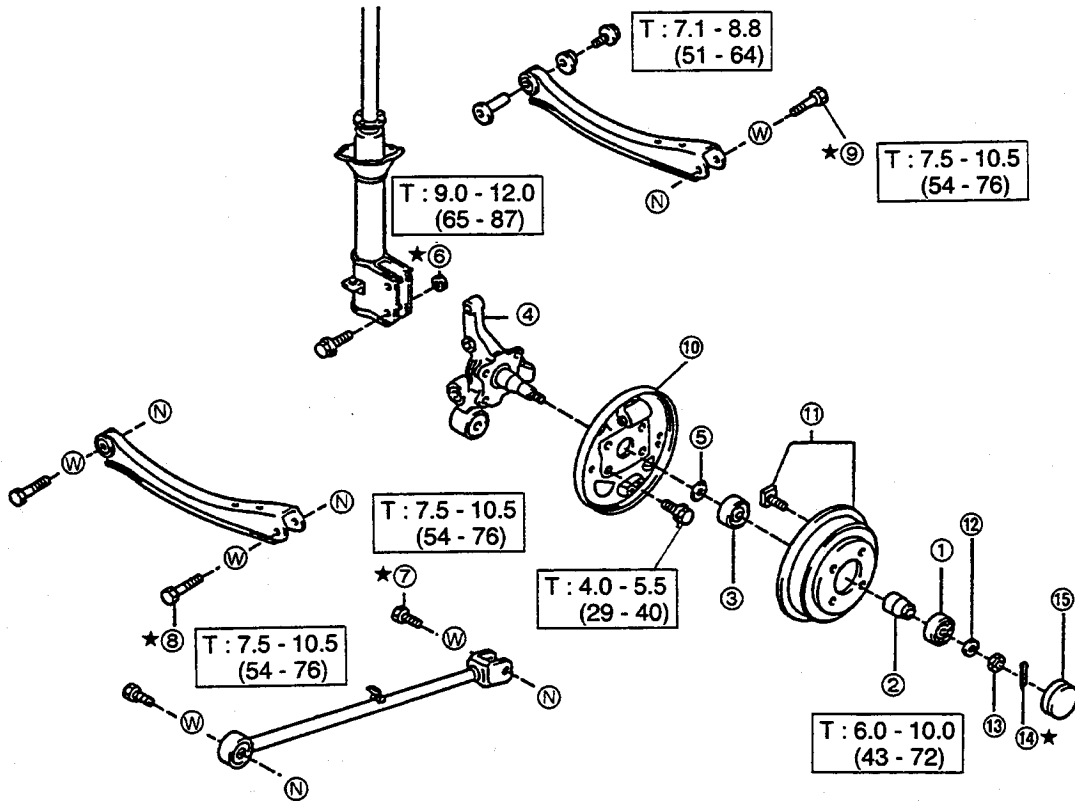

Fig. 6-1

WR-06002

COMPONENTS



T : Tightening torque
Unit: kg-m (ft-lb)
★ : Non-reusable parts

- ① Radial ball bearing
- ② Rear axle bearing outer retainer
- ③ Radial ball bearing
- ④ Rear axle carrier S/A
- ⑤ Rear axle bearing inner retainer
- ⑥ Nut
- ⑦ Bolt
- ⑧ Bolt

- ⑨ Bolt
- ⑩ Rear brake Ay
- ⑪ Rear brake drum
- ⑫ Plate washer
- ⑬ Castle nut
- ⑭ Cotter pin
- ⑮ Grease retainer cap

Fig. 6-2

WR-06003

REAR AXLE & SUSPENSION

REMOVAL

1. Jack up the vehicle at the rear side. Support the body with safety stands.
2. Remove the rear wheel.

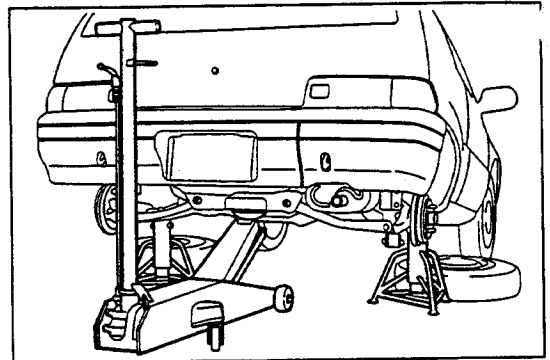

Fig. 6-3

WR-06004

3. Backing plate removal
(Drum brake equipped vehicle)
 - (1) Remove the grease retainer cap.
 - (2) Remove the cotter pin, castle nut and plate washer.

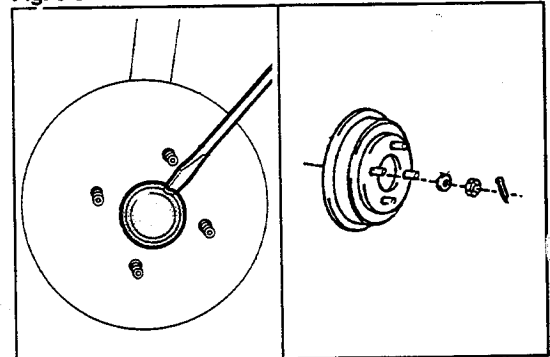

Fig. 6-4

WR-06005

- (3) Remove the brake drum, using the following SST.
Remove the bearing inner retainer.
SST: 09510-87301-000

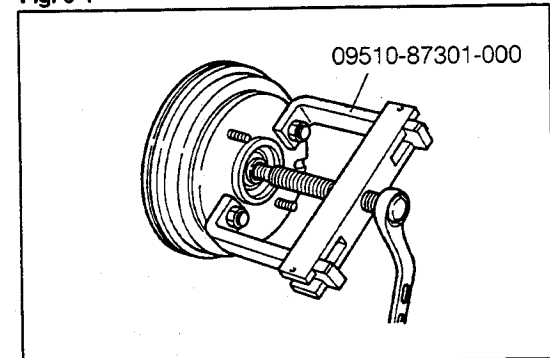

Fig. 6-5

WR-06006

- (4) Disconnect the brake tube from the wheel cylinder, using the following SST.
SST: 09751-36011-000

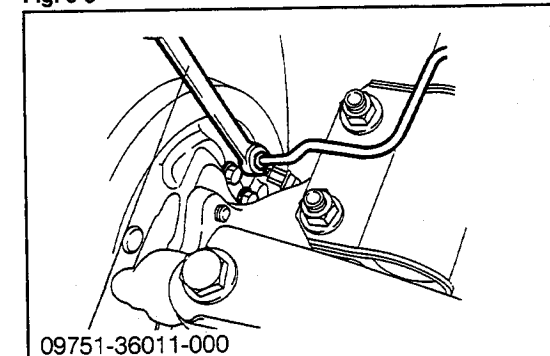

Fig. 6-6

WR-06007

- (5) Remove the backing plate with the brake shoe installed.

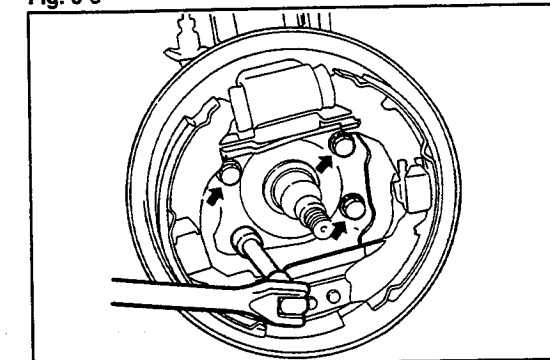

Fig. 6-7

WR-06008

REAR AXLE & SUSPENSION

(Disc brake equipped vehicle)

- (1) Remove the parking cable guide.
- (2) Remove the anti-rattle spring.

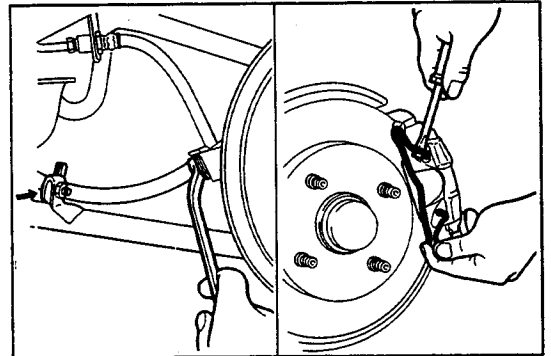

Fig. 6-8

WR-06009

- (3) Remove the caliper.

NOTE:

Suspend the caliper as shown in the right figure.

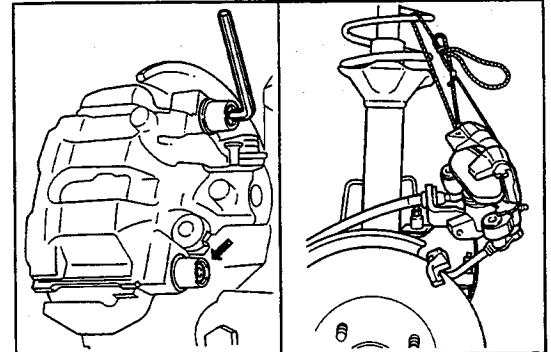

Fig. 6-9

WR-06010

- (4) Remove the caliper support.

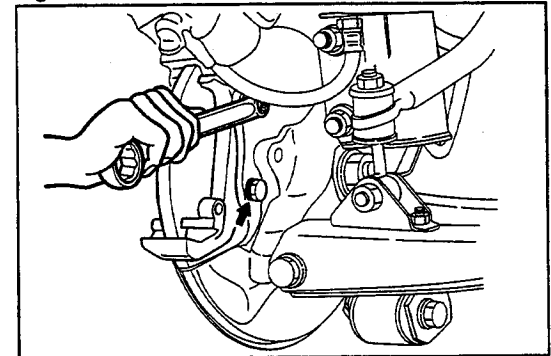

Fig. 6-10

WR-06011

- (5) Remove the grease retainer cap.

- (6) Remove the cotter pin, castle nut and plate washer.

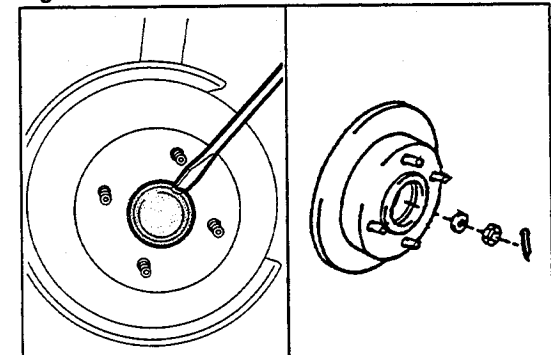

Fig. 6-11

WR-06012

- (7) Remove the disc rotor and bearing inner retainer.

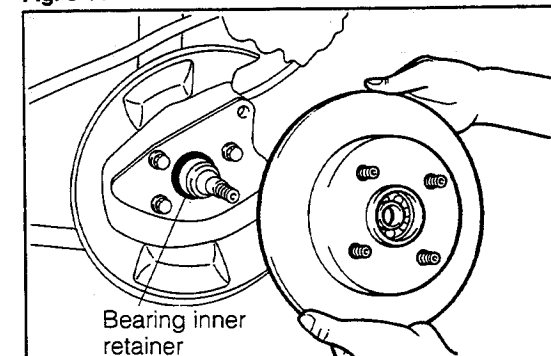

Fig. 6-12

WR-06013

REAR AXLE & SUSPENSION

(8) Remove the backing plate.

4. Axle carrier removal

(1) Remove the attaching bolt and nut of the axle carrier from the strut rod.

(2) Remove the attaching bolt and nut of the axle carrier from the suspension arm No.1.

(3) Remove the attaching bolt and nut of the axle carrier from the suspension arm No.2.

(4) Remove the attaching bolts and nuts of the axle carrier from the shock absorber. Remove the axle carrier.

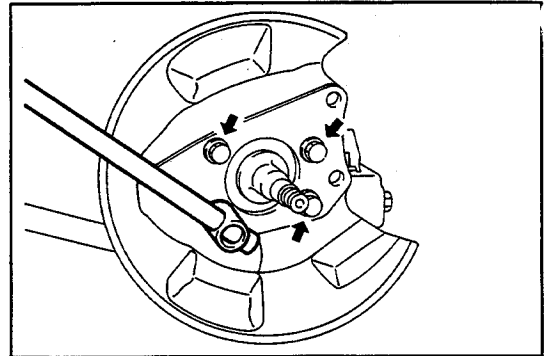

Fig. 6-13

WR-06014

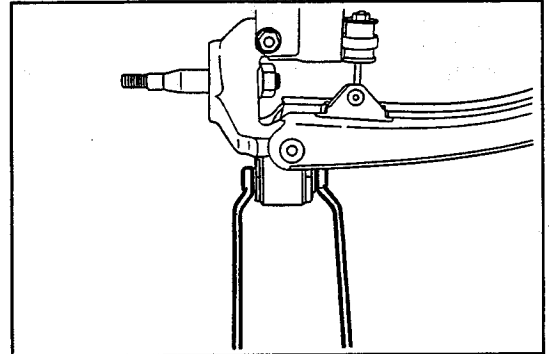

Fig. 6-14

WR-06015

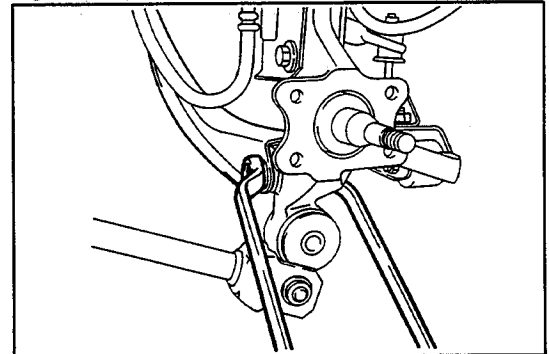

Fig. 6-15

WR-06016

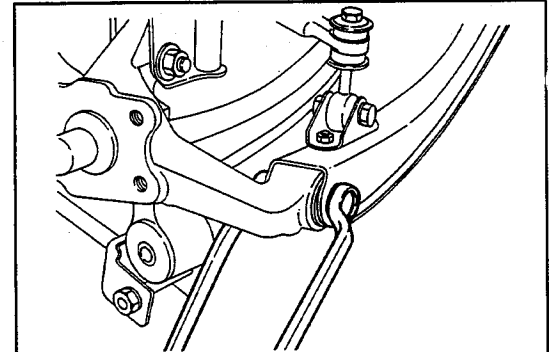

Fig. 6-16

WR-06017

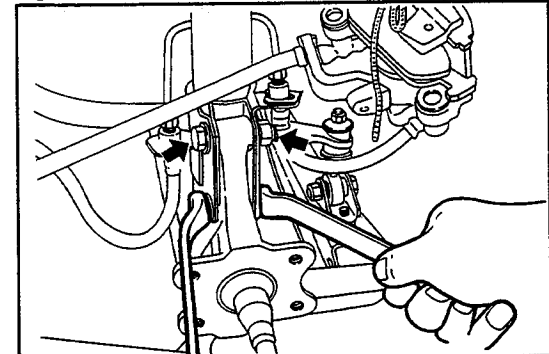

Fig. 6-17

WR-06018

5. Hub bearing removal

- (1) Drive out the inner bearing, using a brass bar. At the same time, drive out the bearing outer retainer, too.
- (2) Drive out the outer bearing, using a brass bar.

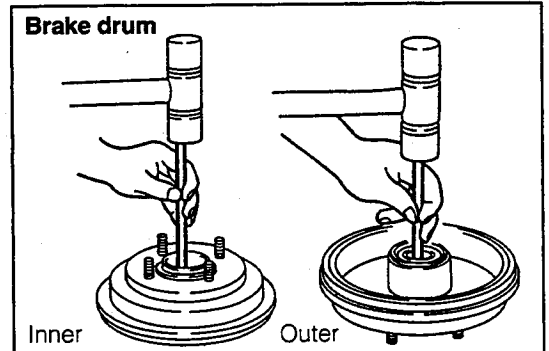

Fig. 6-18

WR-06019

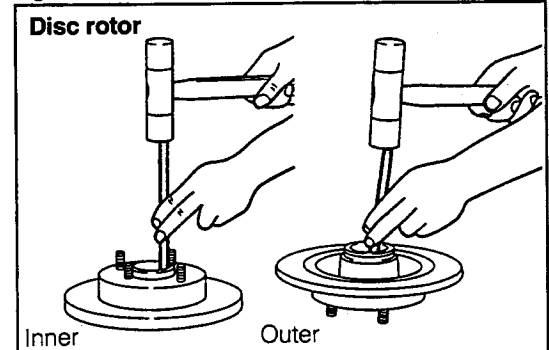

Fig. 6-19

WR-06020

INSPECTION

Inspect the following parts.

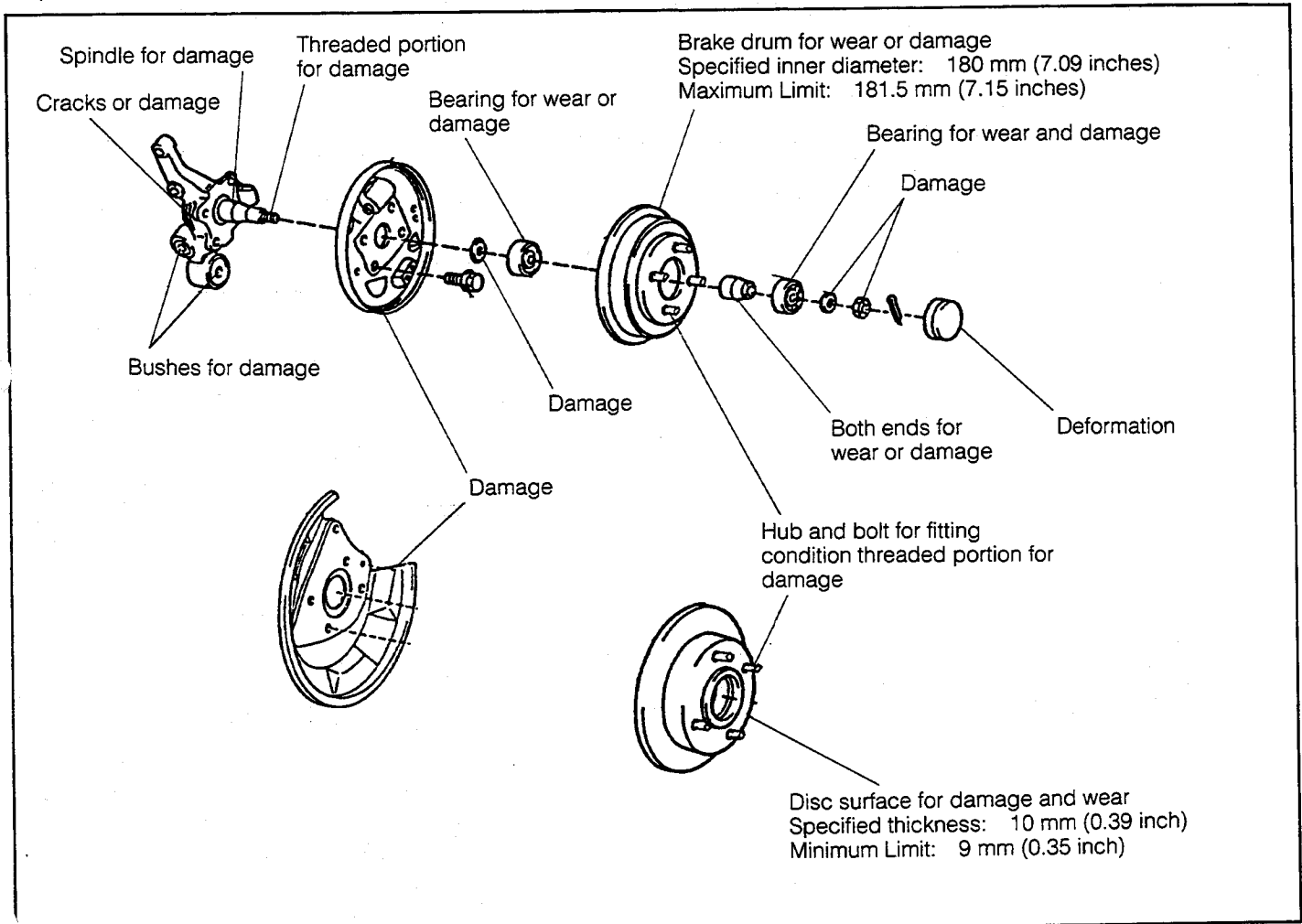

Fig. 6-20

WR-06021

REAR AXLE & SUSPENSION

INSTALLATION

1. Hub bearing installation

Pack the hub and bearing with grease. Then, press the outer bearing, outer retainer and inner bearing, in this order, using a press in conjunction with the following SST.

SST: 09608-12010-000

(For the outer bearing, use No. 13 of the SST set.)

(For the inner bearing, use No. 5 of the SST set.)

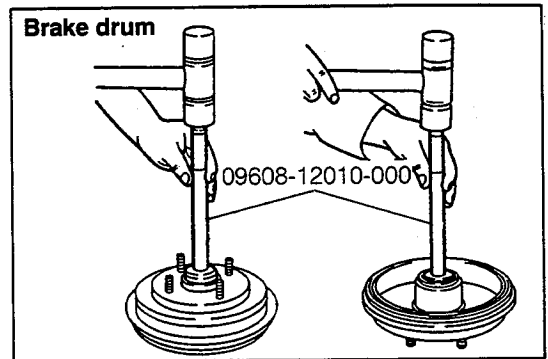

Fig. 6-21

WR-06022

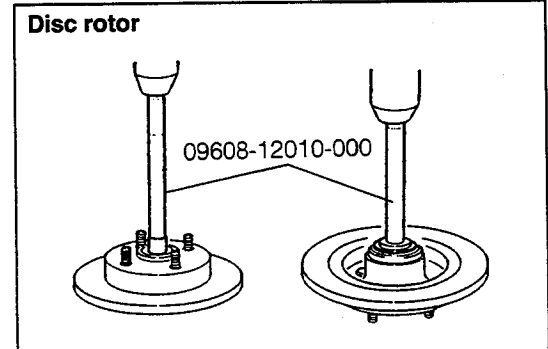

Fig. 6-22

WR-06023

2. Axle carrier installation

NOTE:

As for those suspension-related bolts and nuts on which a friction stabilizing agent has been coated, be certain not to reuse them if they have been once removed

- (1) Mount the axle carrier to the shock absorber.
- (2) Install the attaching bolts and new nuts of the axle carrier. Proceed to tighten them.

Tightening Torque: 9.0 - 12.0 kg-m (65 - 87 ft-lb)

NOTE:

Tighten the bolts and nuts while pushing the axle carrier to the lower side (positive side).

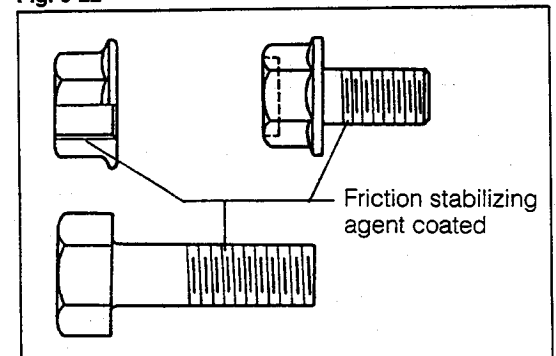

Fig. 6-23

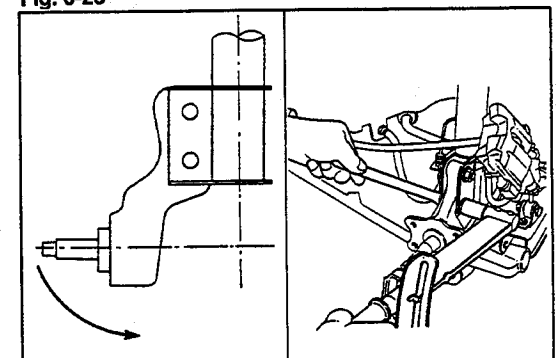

Fig. 6-24

WR-06024

- (3) Mount the axle carrier on the suspension arm No.1. Tighten the new bolt and nut temporarily.
- (4) Mount the axle carrier on the suspension arm No.2. Temporarily tighten the new bolt and nut.

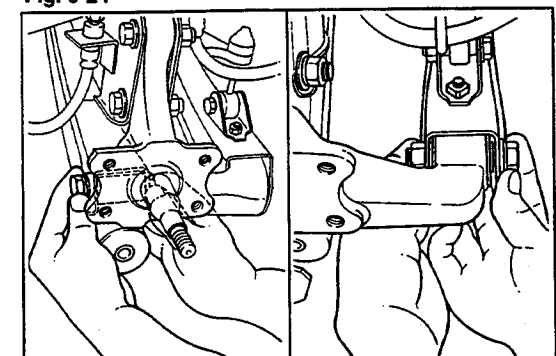

Fig. 6-25

WR-06025

REAR AXLE & SUSPENSION

5. Hub bearing removal

- (1) Drive out the inner bearing, using a brass bar. At the same time, drive out the bearing outer retainer, too.
- (2) Drive out the outer bearing, using a brass bar.

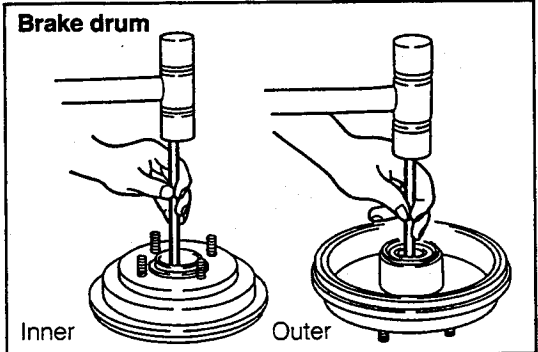

Fig. 6-18 WR-06019

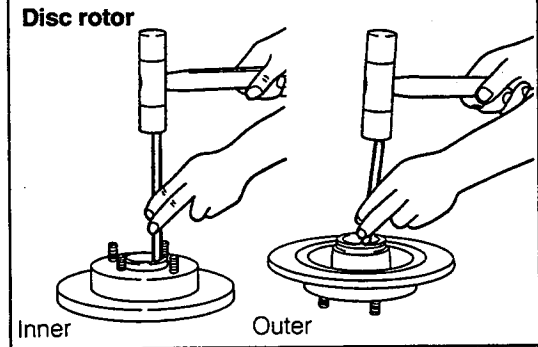

Fig. 6-19 WR-06020

INSPECTION

Inspect the following parts.

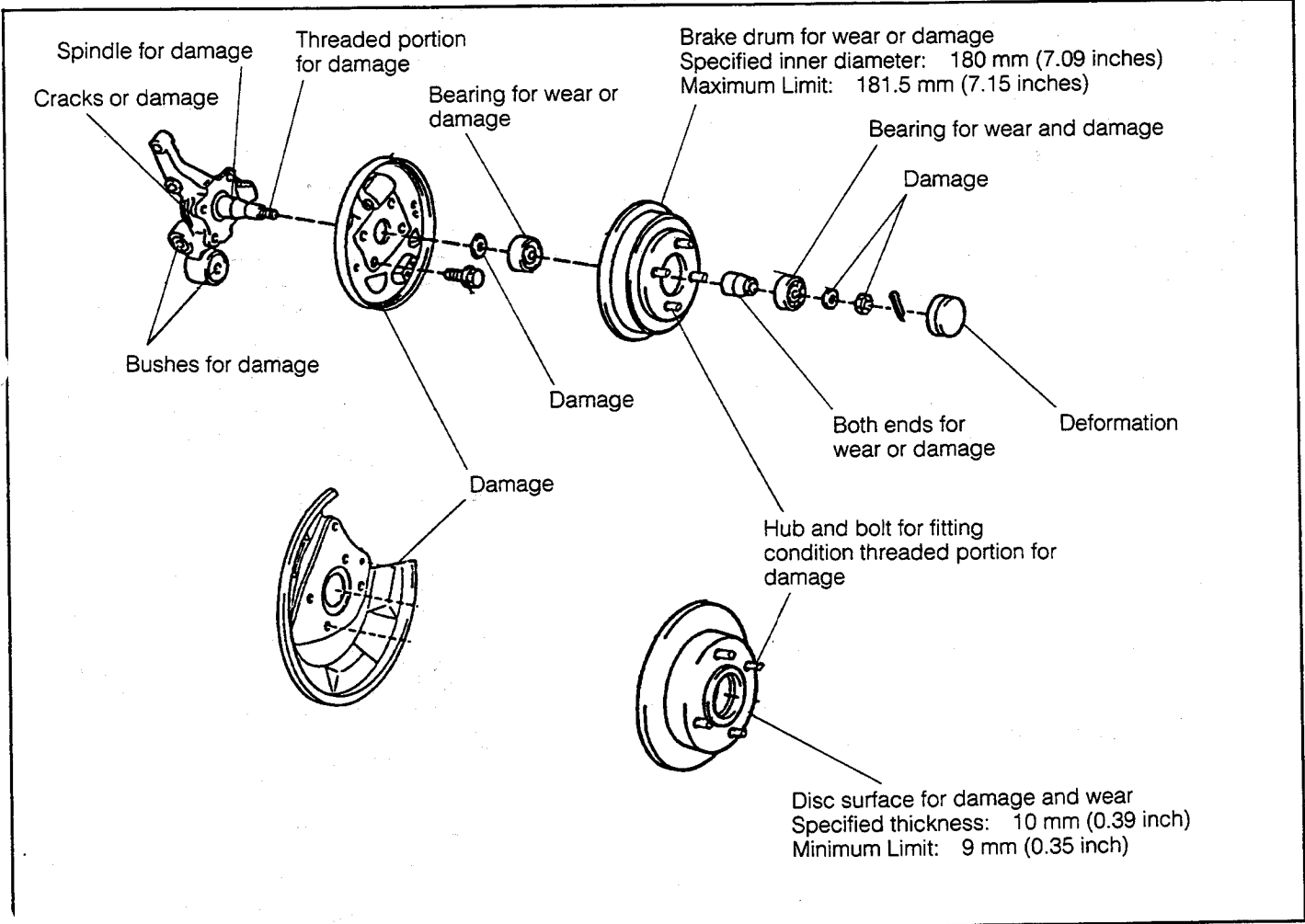

Fig. 6-20

WR-06021

REAR AXLE & SUSPENSION

INSTALLATION

1. Hub bearing installation

Pack the hub and bearing with grease. Then, press the outer bearing, outer retainer and inner bearing, in this order, using a press in conjunction with the following SST.

SST: 09608-12010-000

(For the outer bearing, use No. 13 of the SST set.)

(For the inner bearing, use No. 5 of the SST set.)

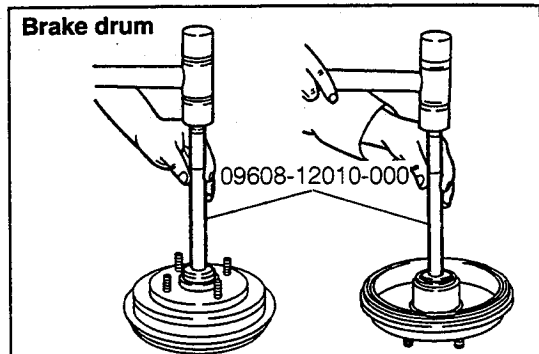

Fig. 6-21

WR-06022

Disc rotor

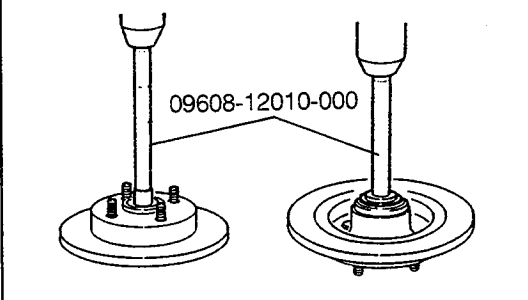

Fig. 6-22

WR-06023

2. Axle carrier installation

NOTE:

As for those suspension-related bolts and nuts on which a friction stabilizing agent has been coated, be certain not to reuse them if they have been once removed

- (1) Mount the axle carrier to the shock absorber.
- (2) Install the attaching bolts and new nuts of the axle carrier. Proceed to tighten them.

Tightening Torque: 9.0 - 12.0 kg-m (65 - 87 ft-lb)

NOTE:

Tighten the bolts and nuts while pushing the axle carrier to the lower side (positive side).

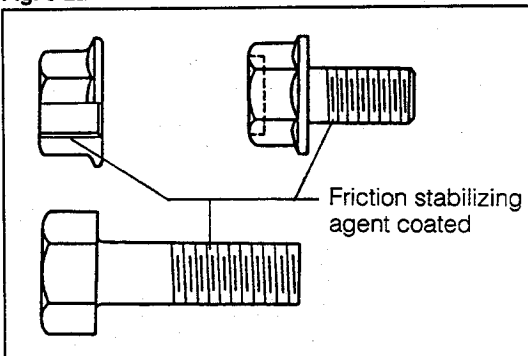

Fig. 6-23

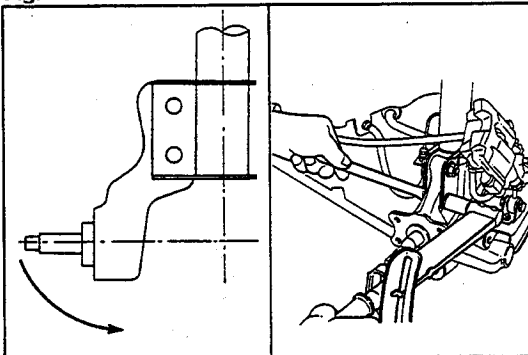

Fig. 6-24

WR-06024

- (3) Mount the axle carrier on the suspension arm No.1. Tighten the new bolt and nut temporarily.
- (4) Mount the axle carrier on the suspension arm No.2. Temporarily tighten the new bolt and nut.

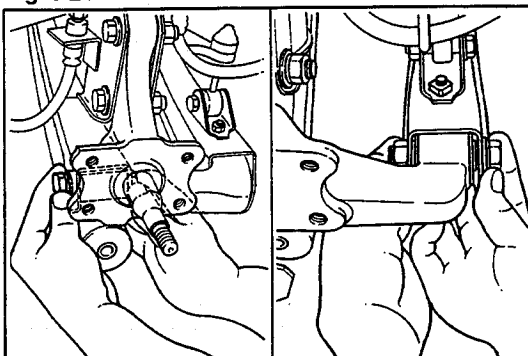

Fig. 6-25

WR-06025

- (5) Mount the axle carrier on the strut rod. Tighten the new bolt and nut temporarily.

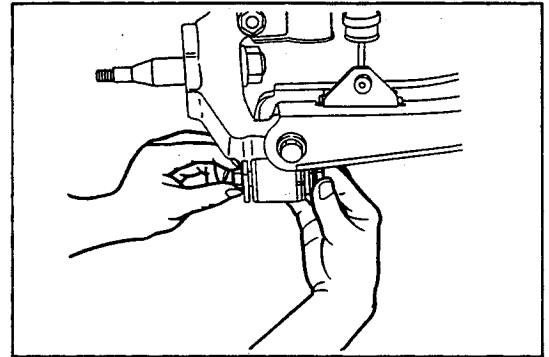

Fig. 6-26

WR-06026

3. Installation of brake drum or disc rotor
(Drum brake equipped vehicle)

- (1) Install the backing plate.

Tightening Torque: 4.0 - 5.5 kg-m (29 - 40 ft-lb)

NOTE:

Be sure to apply DAIHATSU Bond No.4 (999-6304-6323-00) to the mating surface between the rear brake and the axle carrier. During this sealer application, be very careful not to restrict the 5 mm (0.20 inch) dia. grease releasing hole.

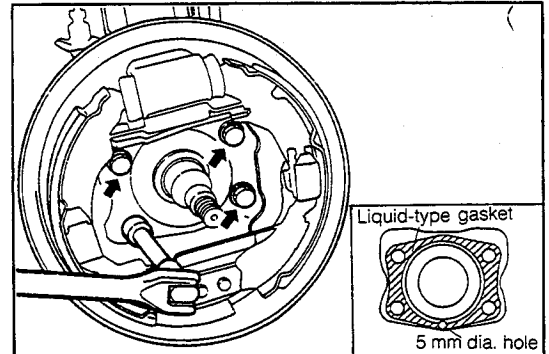

Fig. 6-27

WR-06027

- (2) Install the brake tube to the backing plate.
Tightening Torque: 1.3 - 1.8 kg-m (9.4 - 13.0 ft-lb)
- (3) Install the bearing inner retainer, brake drum, plate washer and castle nut.
- (4) Tighten the castle nut.
Tightening Torque: 6.0 - 10.0 kg-m (43 - 72 ft-lb)
- (5) Install a new cotter pin. Install the grease retainer cap.
- (6) Perform air bleeding for the brake system. (See page 8-5.)

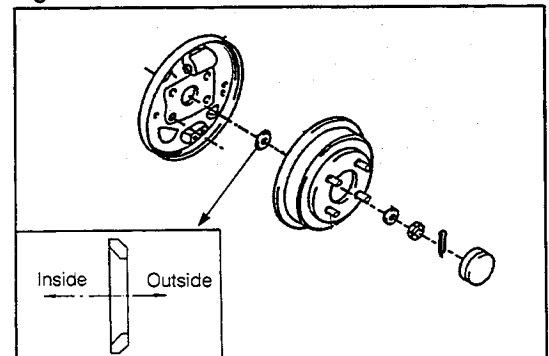

Fig. 6-28

WR-06028

(Disc brake equipped vehicle)

- (1) Install the backing plate.

Tightening Torque: 4.0 - 5.5 kg-m (29 - 40 ft-lb)

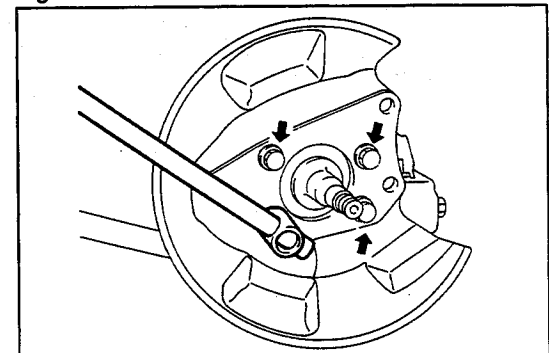

Fig. 6-29

WR-06029

- (2) Install the bearing inner retainer, disc rotor, plate washer and castle nut.
- (3) Tighten the castle nut.
Tightening Torque: 6.0 - 10.0 kg-m (43 - 72 ft-lb)
- (4) Install a new cotter pin. Install the grease retainer cap.

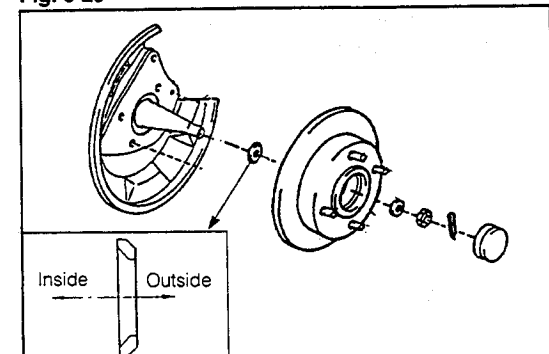

Fig. 6-30

WR-06030

REAR AXLE & SUSPENSION

- (5) Install the caliper support.
Tightening Torque: 4.0 - 5.5 kg-m (29 - 40 ft-lb)
- (6) Install the caliper.

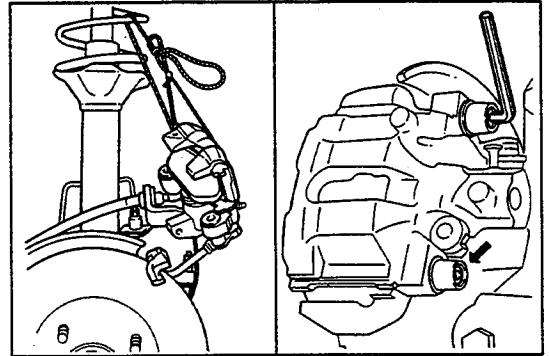

Fig. 6-31

WR-06031

- (7) Install the anti-rattle spring.
- (8) Install the parking cable guide.

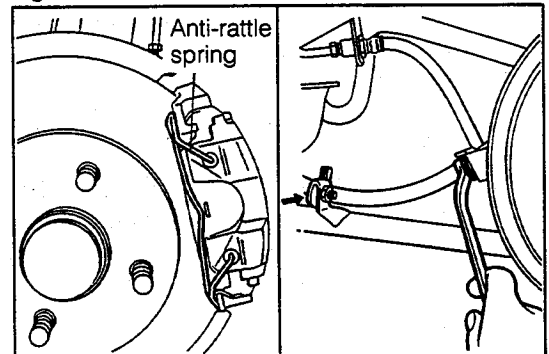

Fig. 6-32

WR-06032

4. Tightening of axle carrier attaching bolts
 - (1) Install the tires.
 - (2) With the vehicle in an unloaded state, jack down the vehicle. Rock the vehicle in an up-and-down direction several times to settle the suspensions.

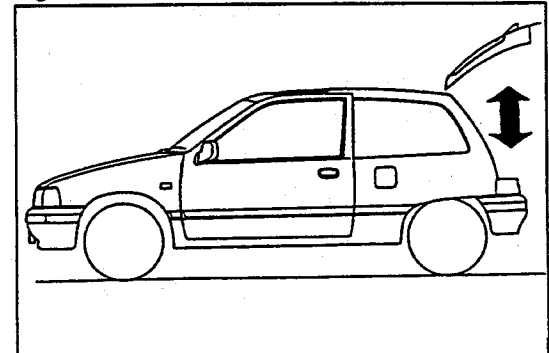

Fig. 6-33

WR-06033

- (3) With the vehicle weight being applied to the suspensions, tighten the bolt and nut of each section.
Tightening Torque: 7.5 - 10.5 kg-m (54 - 76 ft-lb)

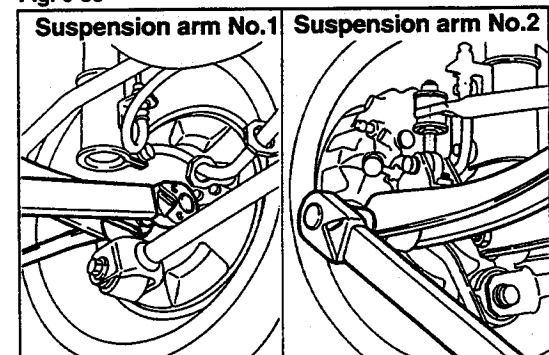

Fig. 6-34

WR-06034

5. Rear wheel alignment inspection
(See Fig. 5-38)

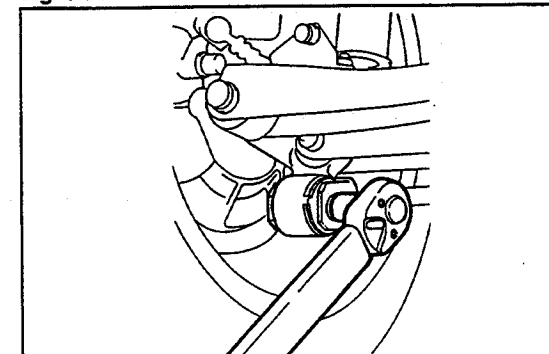

Fig. 6-35

WR-06035

REAR SUSPENSION

SECTIONAL VIEW

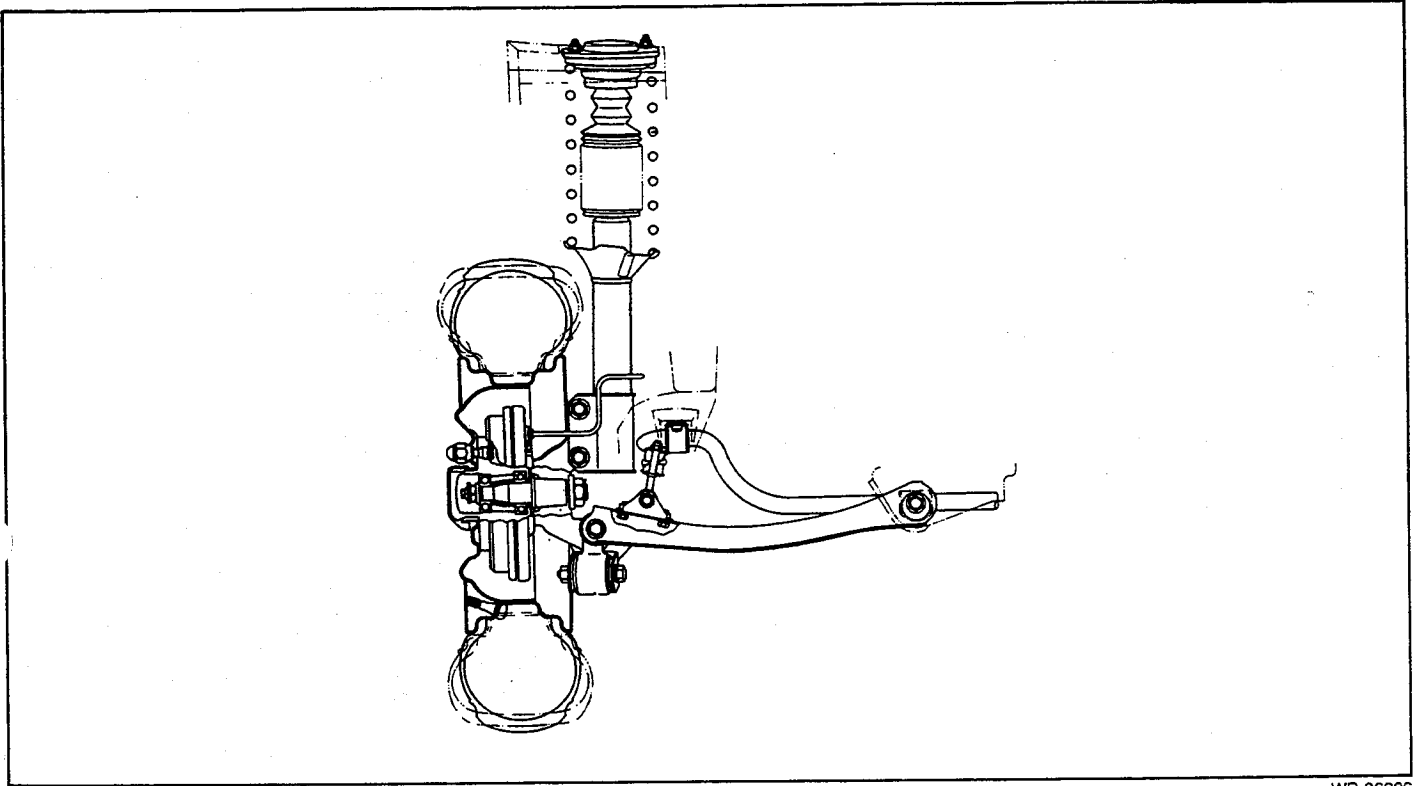

Fig. 6-36

WR-06036

REAR SHOCK ABSORBER

COMPONENTS

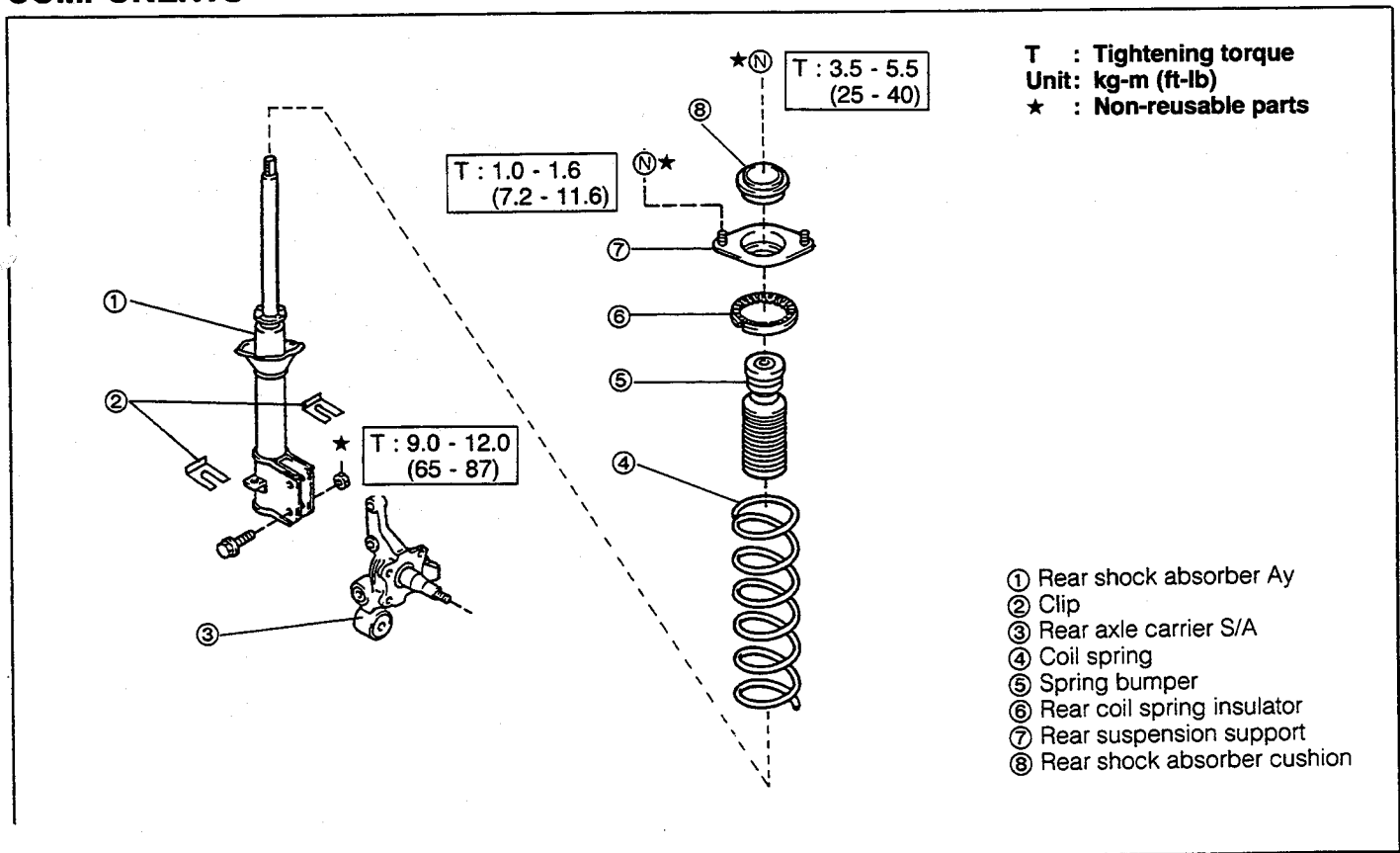

Fig. 6-37

WR-06037

REAR AXLE & SUSPENSION

REMOVAL

1. Jack up the vehicle at the rear section. Support the body with safety stands.
2. Remove the wheel.

3. Removal of brake tube and flexible hose
 - (1) Disconnect the brake tube from the flexible hose.
SST: 09751-36011-000
 - (2) Detach the clip. Disconnect the flexible hose from the shock absorber.

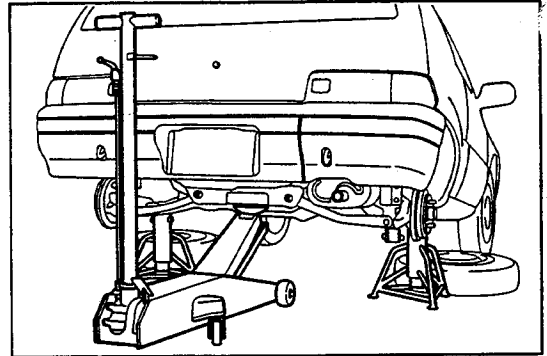

Fig. 6-38

WR-06038

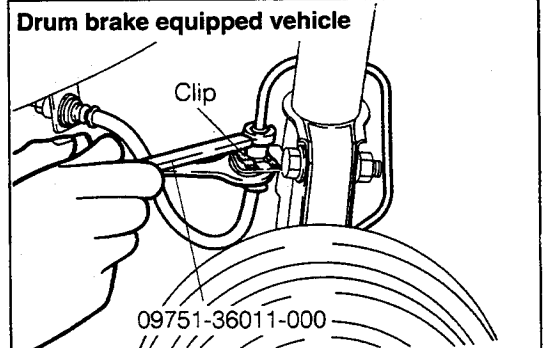

Fig. 6-39

WR-06039

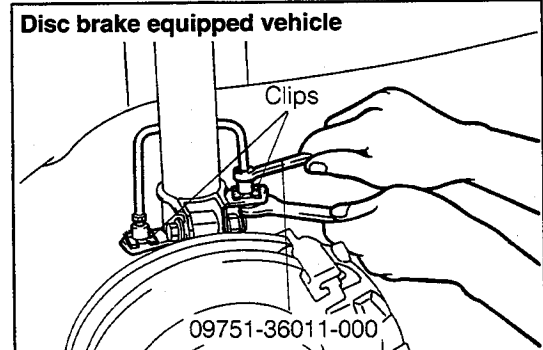

Fig. 6-40

WR-06040

4. Remove the nuts attaching the shock absorber to the axle carrier. Leave the bolts in an inserted condition.

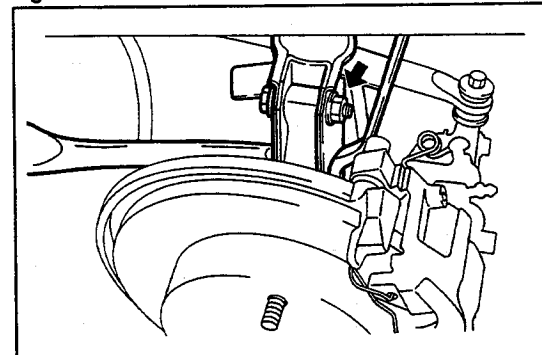

Fig. 6-41

WR-06041

5. Trim removal
 - (1) Remove the package tray.
 - (2) Remove the package tray side trim.

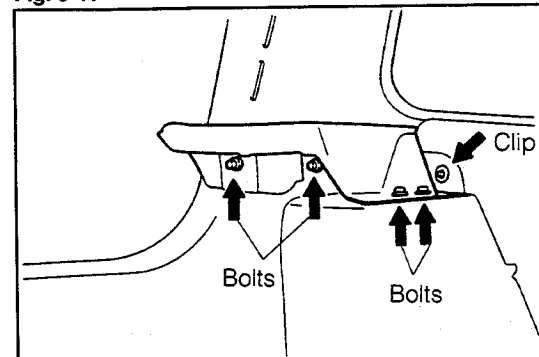

Fig. 6-42

WR-06042

- Slacken the nut attaching the shock absorber to the suspension support.

NOTE:

Do not remove the nut.

- Remove the nuts attaching the suspension support to the body.
- Remove the attaching bolts of the axle carrier and shock absorber. Remove the shock absorber from the body.

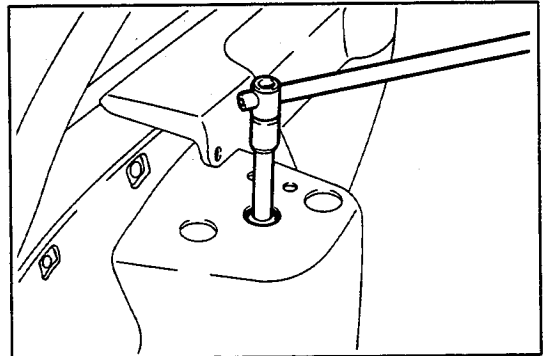

Fig. 6-43

WR-06043

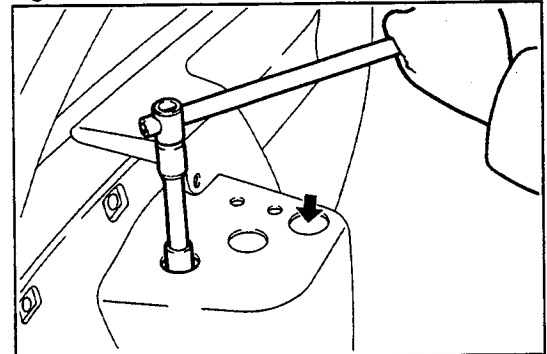

Fig. 6-44

WR-06044

DISASSEMBLY

- Coil spring removal
 - Compress the coil spring, using the following SST.
SST: 09727-87701-000

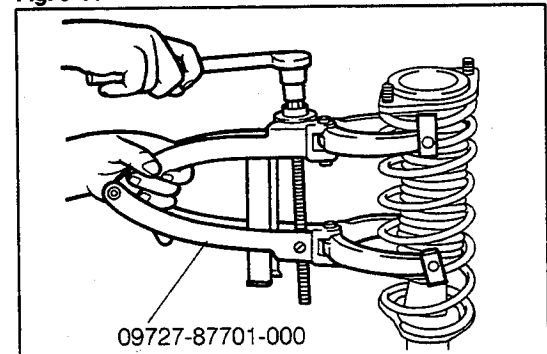

Fig. 6-45

WR-06045

- Remove the nut.

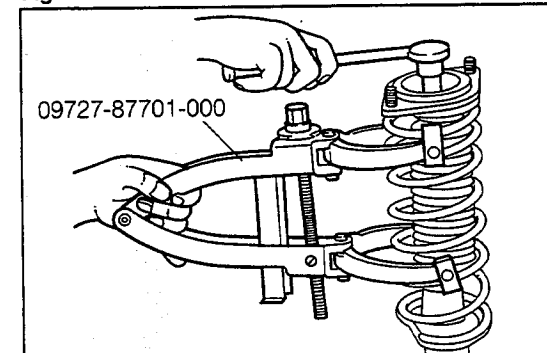

Fig. 6-46

WR-06046

REAR AXLE & SUSPENSION

- (3) Remove the rear shock absorber cushion, rear suspension support, rear coil spring insulator, spring bumper and coil spring.

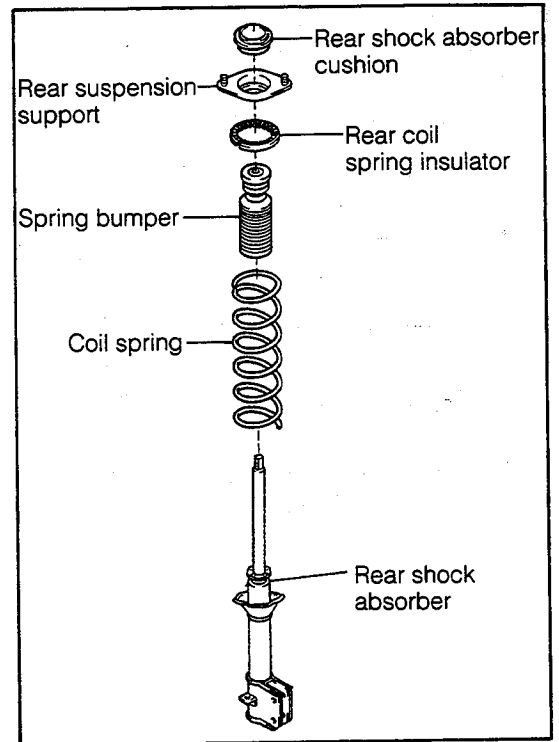

Fig. 6-47

WR-06047

INSPECTION

1. Inspect the following parts.

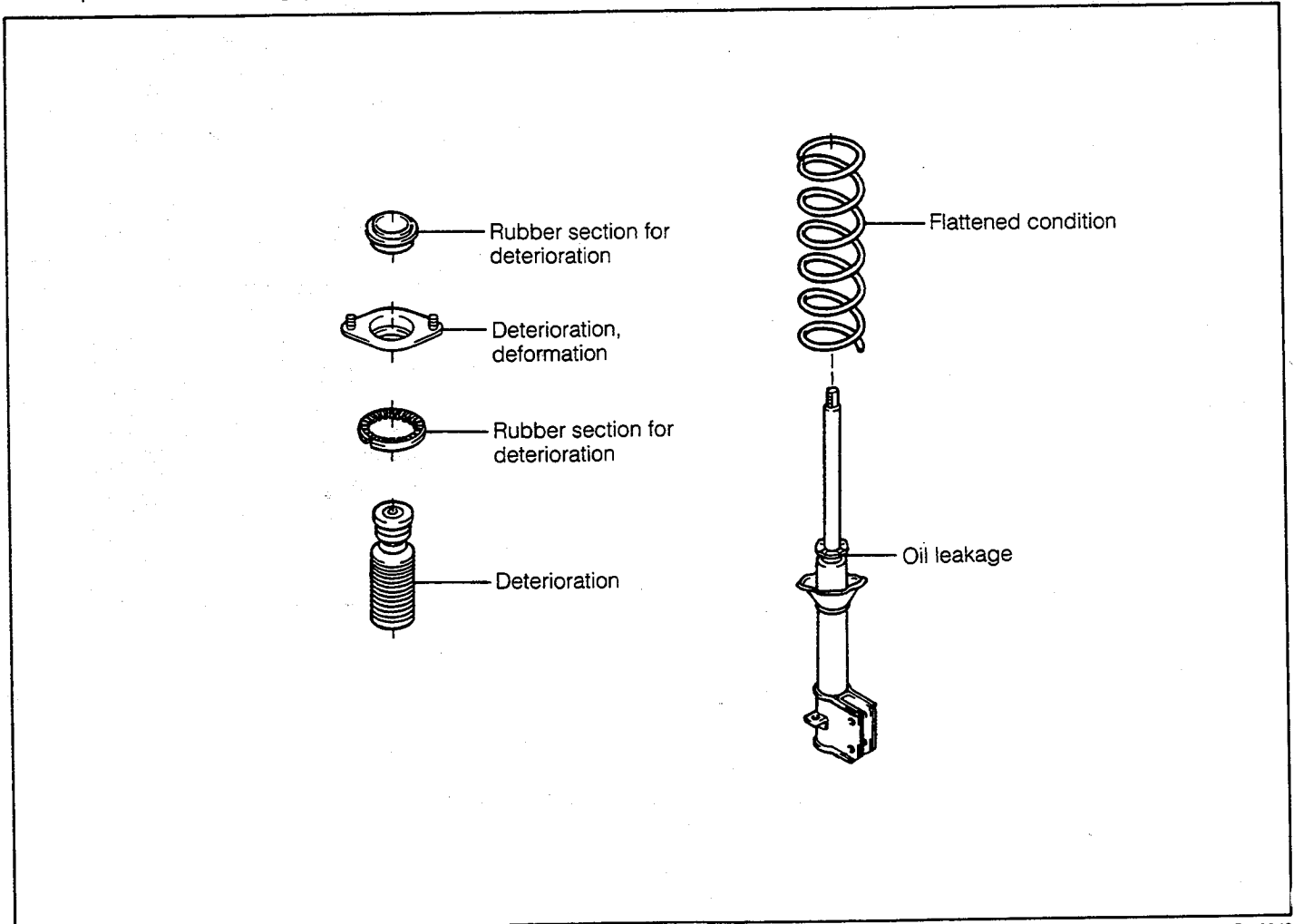

Fig. 6-48

WR-06048

2. Shock absorber operation inspection

- (1) Push or pull the piston rod of the shock absorber at a constant speed. Ensure that the force required to move the rod is uniform over the entire stroke. However, when the piston rod is pulled strongly, the pulling force may become slightly greater over the stroke 30 mm (1.2 inches) toward the end of the pulling stroke. It should be noted that this phenomenon is not abnormal.
- (2) Move the piston rod quickly in a up-and-down direction with a stroke of 5 - 10 mm (0.2 - 0.4 inch). Ensure that the force required to move the rod will not change.
- (3) If any abnormal feeling or noise is encountered during the inspection above, replace the shock absorber.

NOTE:

- Perform this inspection after the piston rod has been moved in a up-and-down direction three or four times.
- When the gas filling type shock absorber is replaced, previous to the disposal, be sure to release the gas from the shock absorber.

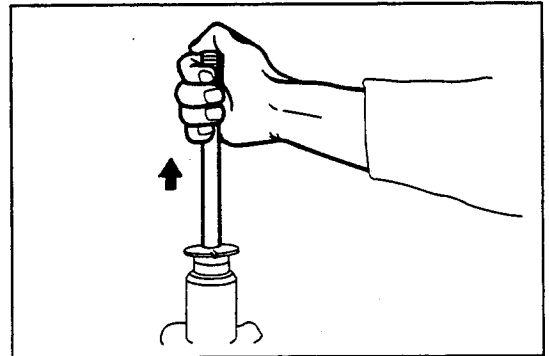

Fig. 6-49

WR-06049

ASSEMBLY

1. Assembly of coil spring

- (1) Install the spring bumper at a point below the cut-out section of the piston rod.
- (2) Compress the coil spring, using the following SST. Install it to the shock absorber.
SST: 09727-87701-000

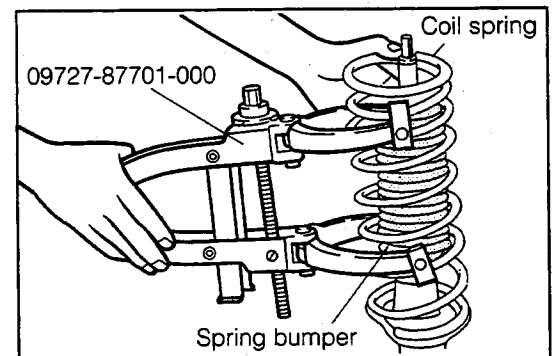

Fig. 6-50

WR-06050

- (3) Install the rear shock absorber cushion to the rear suspension support.
- (4) Install the rear coil spring insulator to the rear suspension support.

NOTE:

Be sure to align the cut-out section of the rear coil spring insulator with the stud bolt section of the rear suspension support during the assembly.

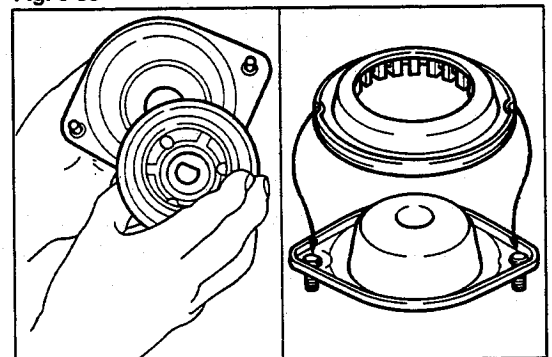

Fig. 6-51

WR-06051

- (5) Install the rear suspension support.

NOTE:

- Be sure to align the cut-out section of the rear suspension support with that of the piston rod during the assembly.
- Align the rear suspension support on the shock absorber lower bracket, as shown in Fig. 6-53.

- (6) Fit the suspension support. Tighten it temporarily, using a new nut.

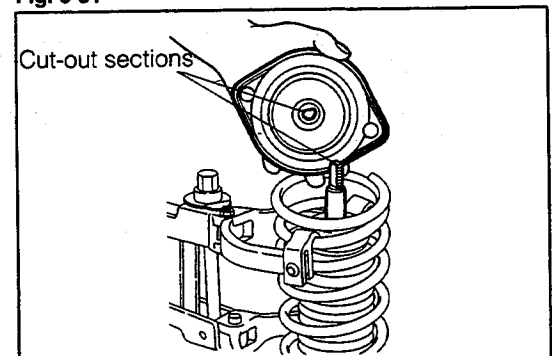

Fig. 6-52

WR-06052

REAR AXLE & SUSPENSION

- (7) Align the coil spring end with the recessed sections of the upper and lower seats. Proceed to remove the SST.

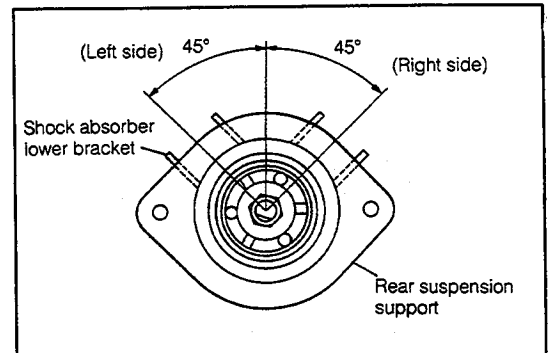

Fig. 6-53

WR-06053

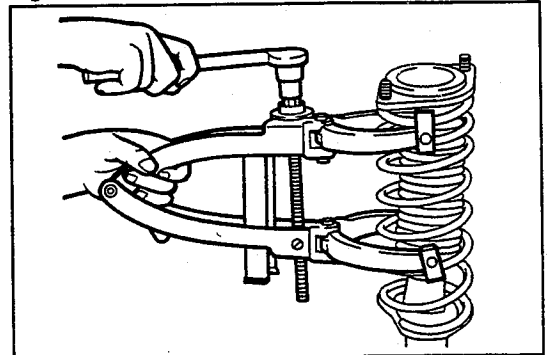

Fig. 6-54

WR-06054

INSTALLATION

1. Install the suspension support to the body, using a new nuts.

Tightening Torque: 1.0 - 1.6 kg-m (7.2 - 11.6 ft-lb)

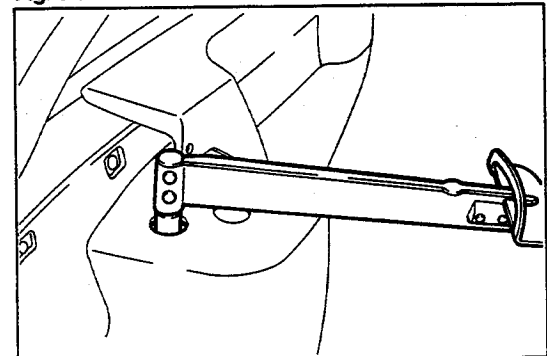

Fig. 6-55

WR-06055

2. Mount the axle carrier on the shock absorber. Fit the bolts and new nuts in position and tighten them.

Tightening Torque: 9.0 - 12.0 kg-m (65 - 87 ft-lb)

NOTE:

- The steering carrier attaching nuts are special nuts on which a friction stabilizing agent has been coated. Hence, be certain not to reuse them.
- Tighten the bolts and nuts while pushing the axle carrier to the lower side (positive side).

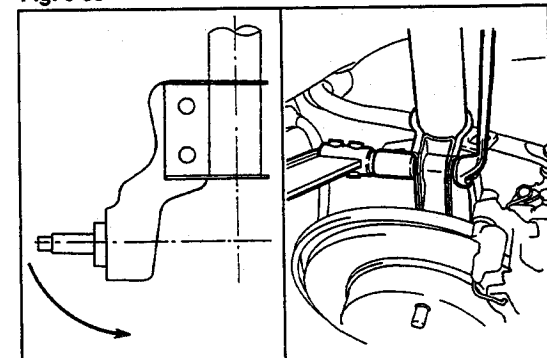

Fig. 6-56

WR-06056

3. Install the flexible hose and brake tube, as follows:
 - (1) Install the flexible hose to the shock absorber. Secure it with the clip.
 - (2) Install the brake tube to the flexible hose.

SST: 09751-36011-000

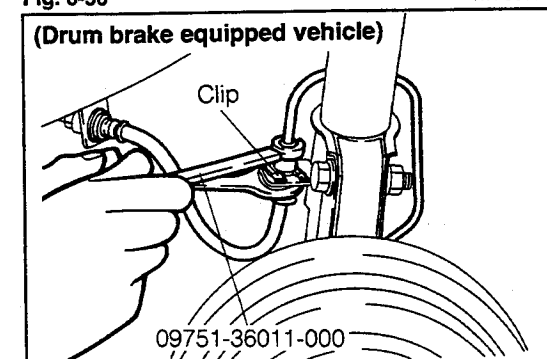

Fig. 6-57

WR-06057

REAR AXLE & SUSPENSION

4. Tighten the suspension support attaching nut.
Tightening Torque: 3.5 - 5.5 kg-m (25 - 40 ft-lb)

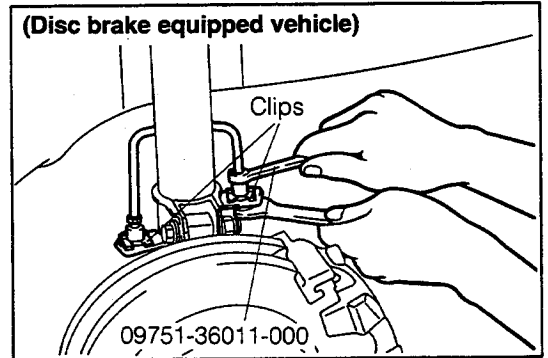

Fig. 6-58

WR-06058

5. Trim installation
 - (1) Install the package tray side trim.
 - (2) Install the package tray.

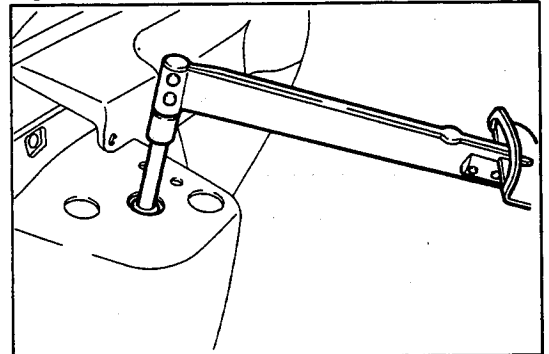

Fig. 6-59

WR-06059

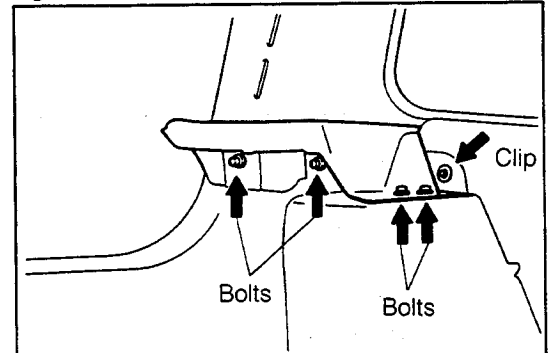

Fig. 6-60

WR-06060

6. Perform air bleeding for the brake system. (See page 8-5.)
7. Install the wheels. Jack down the vehicle.
8. Check the rear wheel alignment. (See page 5-38.)

WR-06061

REAR AXLE & SUSPENSION

SUSPENSION ARM COMPONENTS

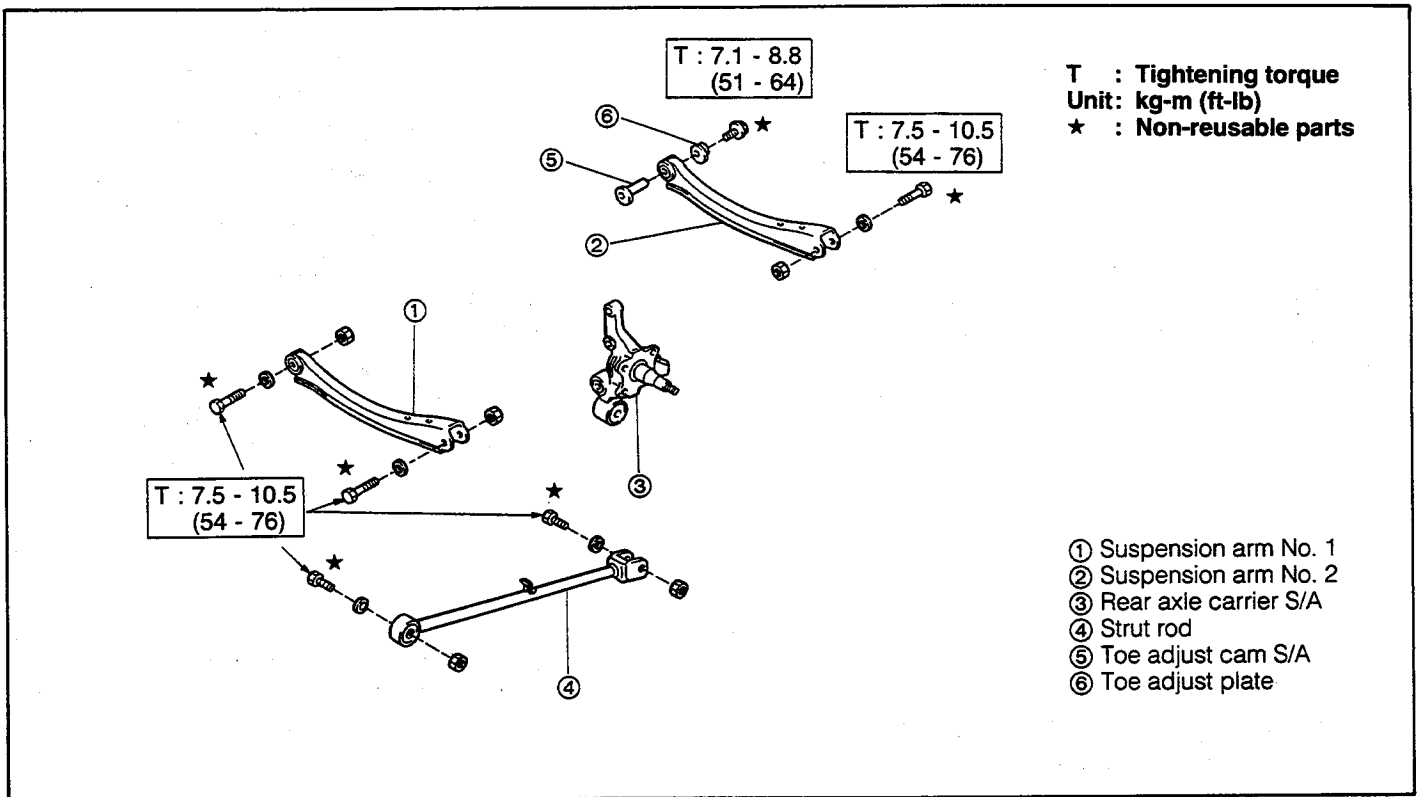

Fig. 6-61

WR-06062

REMOVAL

1. Jack up the vehicle.
 - (1) Jack up the vehicle and support the body with safety stands.
 - (2) Remove the wheel.
2. Removal of suspension arm No.2
 - (1) Remove the attaching bolt and nut of the stabilizer link.
 - (2) Remove the attaching bolt and nut of the suspension arm at the axle carrier side.

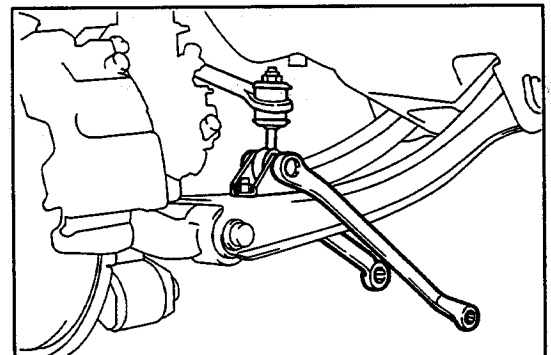

Fig. 6-62

WR-06063

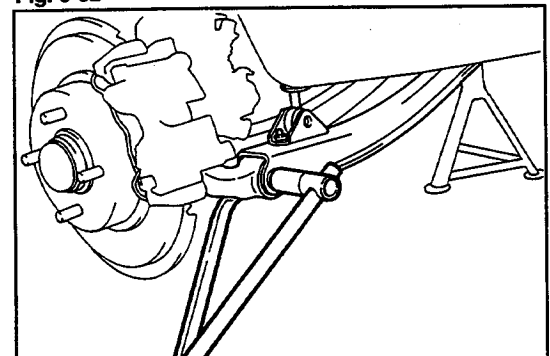

Fig. 6-63

WR-06064

REAR AXLE & SUSPENSION

- (3) Remove the attaching bolt of the suspension arm and cam at the body side. Then, remove the suspension arm.

NOTE:

Put a mate mark on the body bracket and the toe adjusting cam so that the mark may be used as guide during the installation.

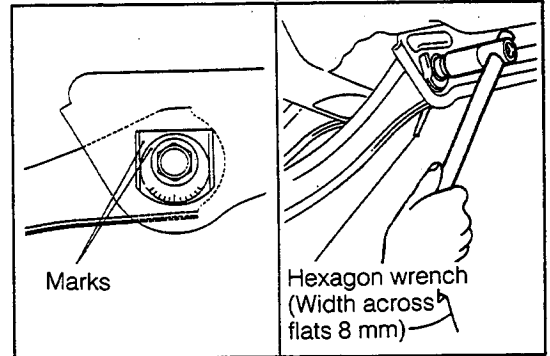

Fig. 6-64

WR-06065

- (4) Remove the rear stabilizer bar bracket from the suspension arm.

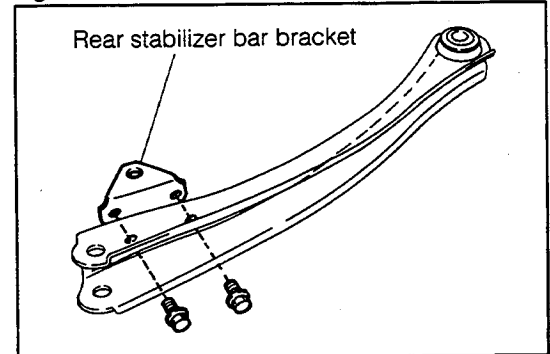

Fig. 6-65

WR-06066

3. Removal of suspension arm No.1

- (1) Remove the attaching bolt and nut of the suspension arm at the axle carrier side.

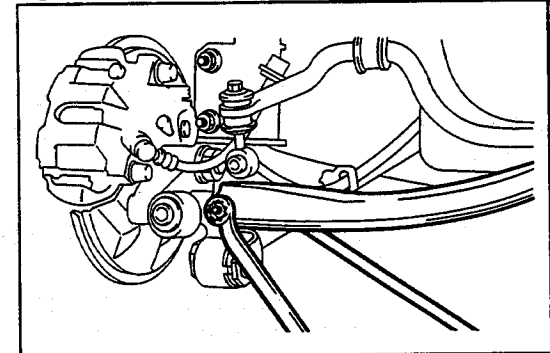

Fig. 6-66

WR-06067

- (2) Remove the attaching bolt and nut of the suspension arm at the body side. Then, remove the suspension arm.

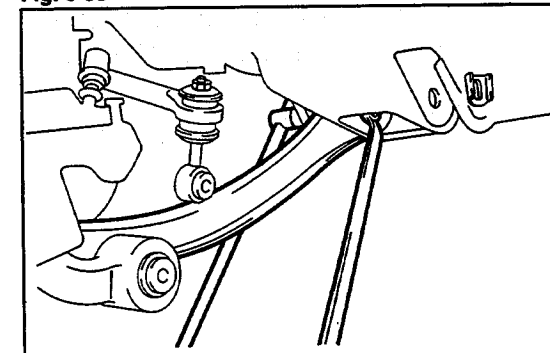

Fig. 6-67

WR-06068

REAR AXLE & SUSPENSION

INSPECTION

Inspect the parts as right figure.

INSTALLATION

NOTE:

The suspension arm attaching bolts are special bolts on which a friction stabilizing agent has been coated. Hence, be certain not to reuse them.

1. Installation of suspension arm No.1
 - (1) Tighten the suspension arm to the body temporarily with the new bolt and nut.
 - (2) Tighten the suspension arm to the axle carrier temporarily with the new bolt and nut.

2. Installation of suspension arm No.2
 - (1) Install the rear stabilizer bar bracket to the suspension arm.
Tightening Torque: 1.0 - 1.6 kg-m (7.2 - 11.6 ft-lb)

 - (2) Mount the suspension arm on the body.
 - (3) Tighten the suspension arm to the body temporarily with the new bolt and cam.
 - (4) Prior to secure tightening, align the mate marks on the toe adjuster cam and body with each other.

Suspension arm No.2

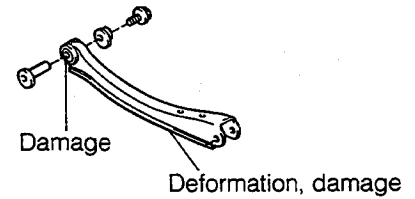

Suspension arm No.1

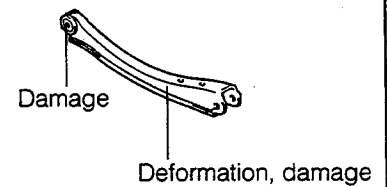

Fig. 6-68

WR-06069

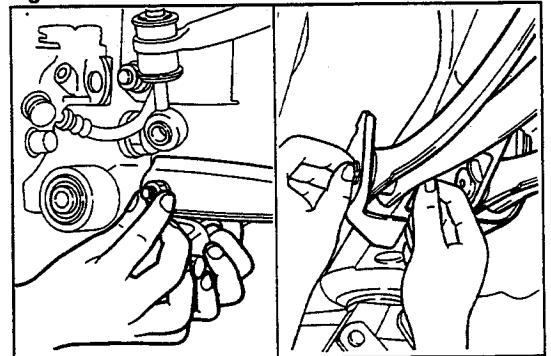

Fig. 6-69

WR-06070

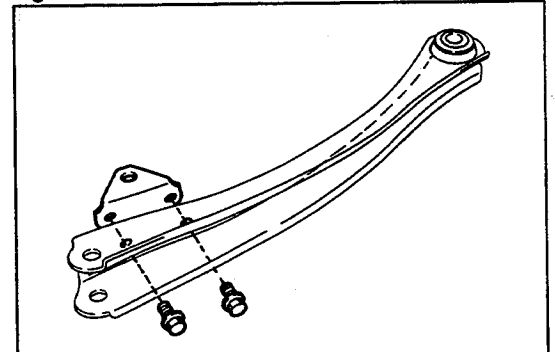

Fig. 6-70

WR-06071

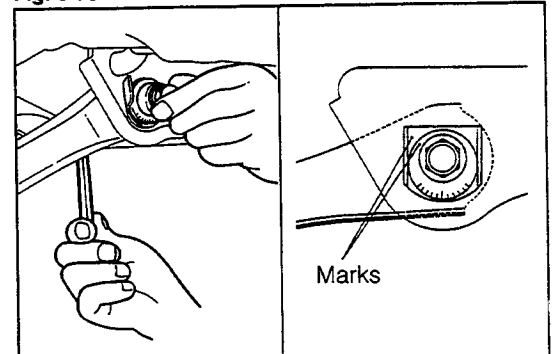

Fig. 6-71

WR-06072

REAR AXLE & SUSPENSION

- (5) Tighten the suspension arm to the axle carrier temporarily with the new bolt and nut.

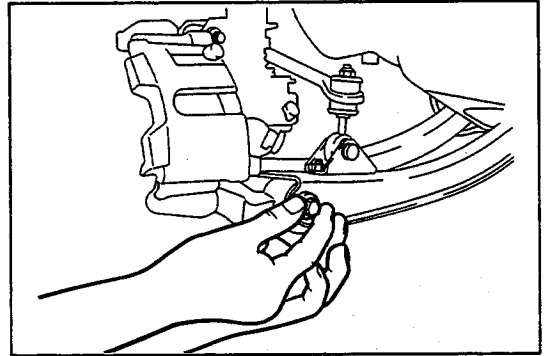

Fig. 6-72

WR-06073

- (6) Tighten the attaching bolt and nut of the stabilizer link to the specified torque.

Tightening Torque: 1.9 - 3.1 kg-m (14 - 22 ft-lb)

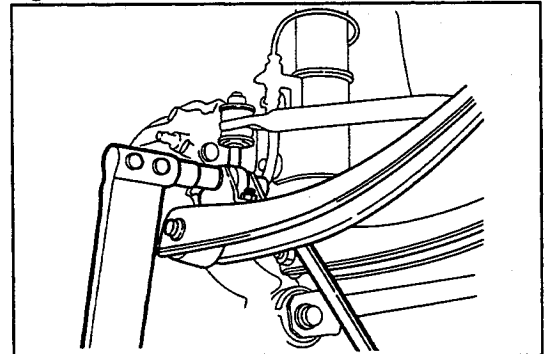

Fig. 6-73

WR-06074

3. Tightening of suspension arm attaching bolt

- (1) Install the wheel.
(2) With the vehicle in an unloaded state, jack down the vehicle. Rock the vehicle in an up-and-down direction a few times so as to settle the suspension.

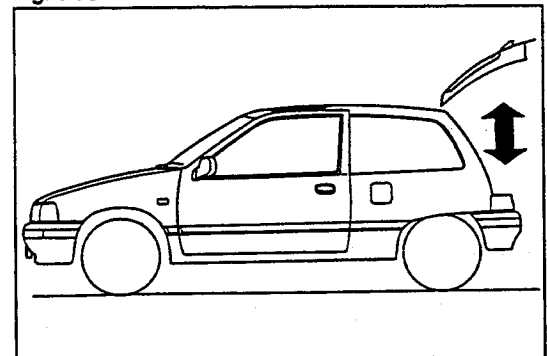

Fig. 6-74

WR-06075

- (3) With the vehicle weight applied to the suspension, tighten the bolts and nuts.

[Suspension arm No.1]

(Axle carrier side)

Tightening Torque: 7.5 - 10.5 kg-m (54 - 76 ft-lb)

(Body side)

Tightening Torque: 7.5 - 10.5 kg-m (54 - 76 ft-lb)

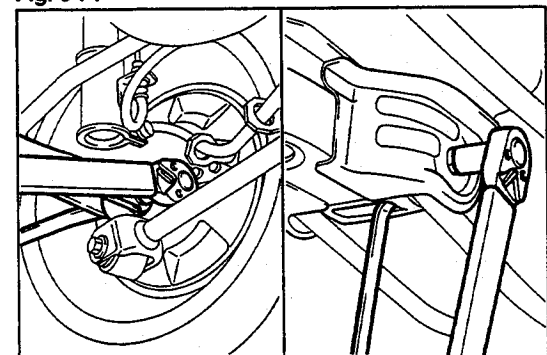

Fig. 6-75

WR-06076

[Suspension arm No.2]

(Axle carrier side)

Tightening Torque: 7.5 - 10.5 kg-m (54 - 76 ft-lb)

(Body side)

Tightening Torque: 7.1 - 8.8 kg-m (51 - 64 ft-lb)

4. Check the rear wheel alignment.
(See page 5-38.)

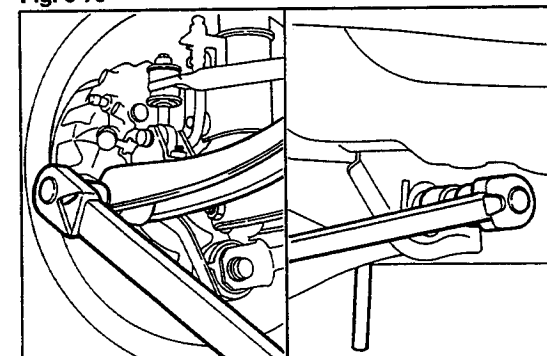

Fig. 6-76

WR-06077

REAR AXLE & SUSPENSION

STRUT ROD

REMOVAL

1. Jack up the vehicle.
 - (1) Jack up the vehicle. Support the body with safety stands.
 - (2) Remove the wheel.
2. Strut rod removal
 - (1) Remove the attaching bolt and nut of the strut rod at the axle carrier side.
 - (2) Remove the attaching bolt and nut of the strut rod at the body side. Then, remove the strut rod.

WR-06078

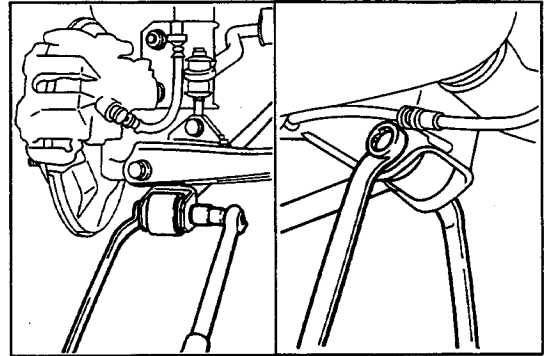

Fig. 6-77

WR-06079

INSPECTION

Inspect the parts as right figure.

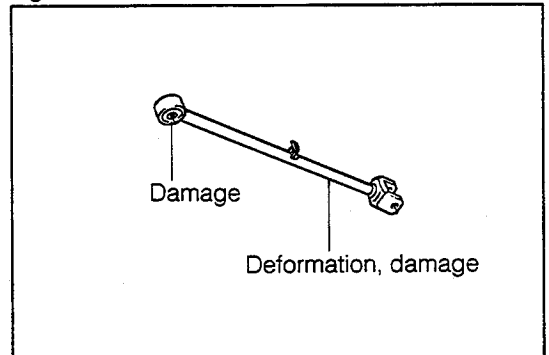

Fig. 6-78

WR-06080

INSTALLATION

1. Strut rod installation
 - (1) Tighten the strut rod to the body temporarily with the new bolt and nut.
 - (2) Tighten the strut rod to the axle carrier temporarily with the new bolt and nut.

NOTE:

The strut rod attaching bolts are special bolts on which a friction stabilizing agent has been coated. Hence, be certain not to reuse them.

2. Tightening of strut rod attaching bolt
 - (1) Install the wheel.
 - (2) With the vehicle in an unloaded state, jack down the vehicle. Rock the vehicle in an up-and-down direction a few times so as to settle the suspension.

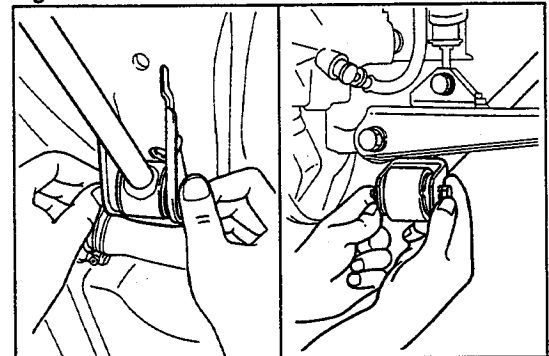

Fig. 6-79

WR-06081

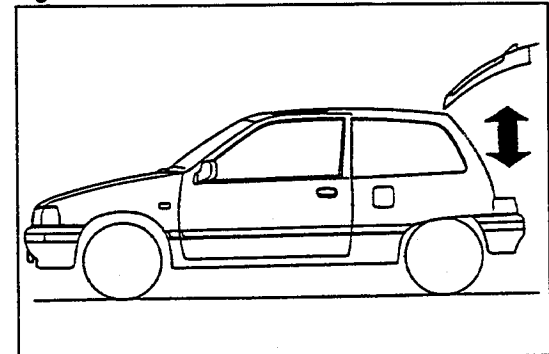

Fig. 6-80

WR-06082

- (3) With the vehicle weight applied to the suspension, tighten the bolt and nut.
Tightening Torque: 7.5 - 10.5 kg-m (54 - 76 ft-lb)

3. Check the rear wheel alignment. (See page 5-38.)

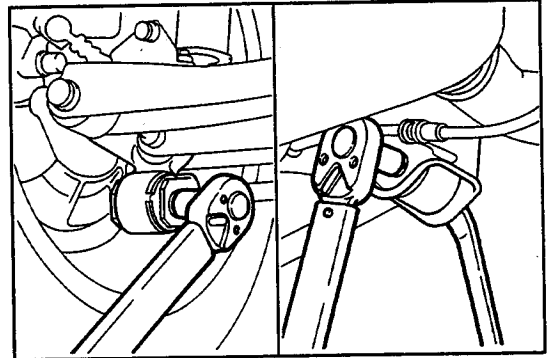
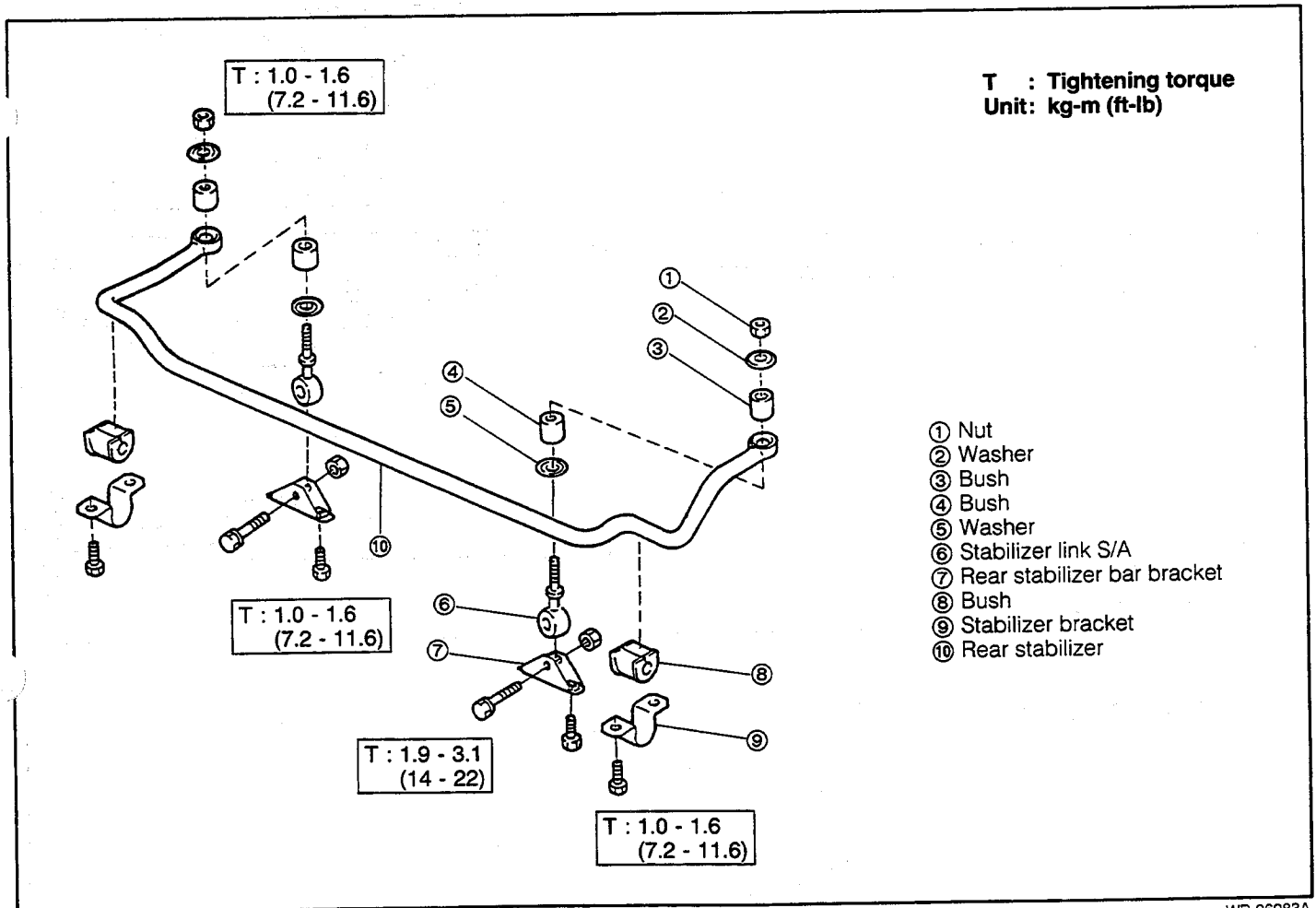

Fig. 6-81

WR-06083

STABILIZER BAR COMPONENTS



WR-06083A

REMOVAL

1. Jack up the vehicle. Support the body with safety stands.
2. Stabilizer bar removal
 - (1) Remove the stabilizer bar attaching nuts from the stabilizer link.

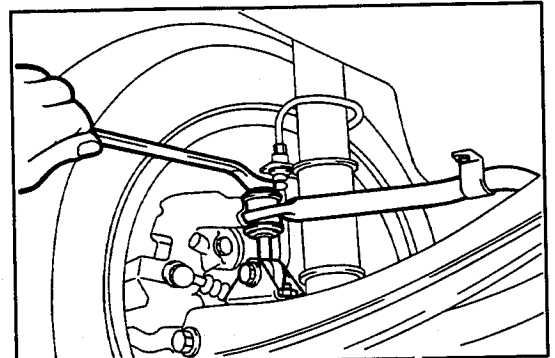

Fig. 6-83

WR-06084

REAR AXLE & SUSPENSION

- (2) Remove the stabilizer bar attaching bolts at the body side. Remove the stabilizer bar.

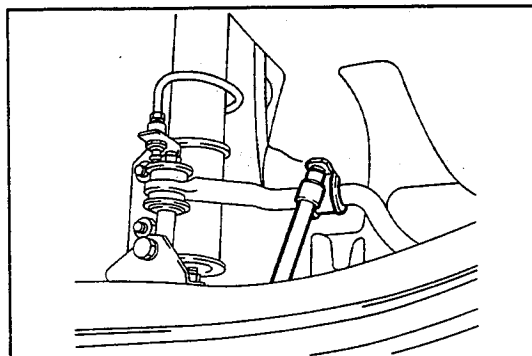

Fig. 6-84

WR-06085

- (3) Remove the attaching bolts and nuts of the stabilizer link. Remove the stabilizer link.

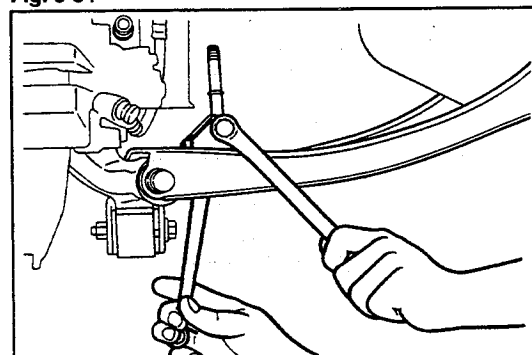

Fig. 6-85

WR-06086

- (4) Remove the rear stabilizer bar bracket attaching bolts. Proceed to remove the stabilizer bar bracket.

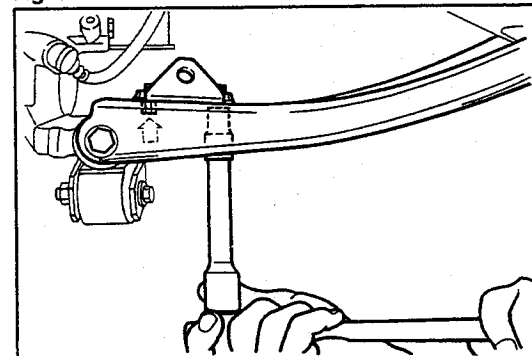

Fig. 6-86

WR-06087

INSPECTION

Inspect the following parts.

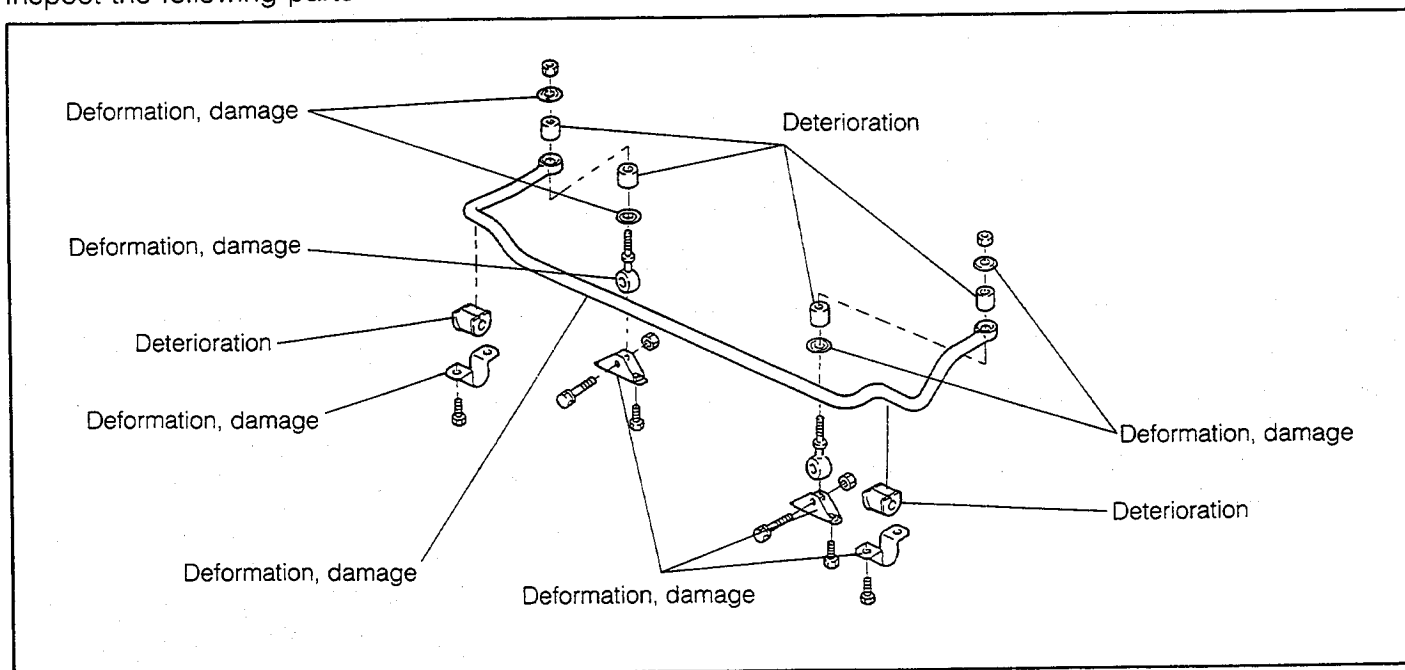

Fig. 6-87

WR-06088

INSTALLATION

1. Stabilizer bar installation

- (1) Install the rear stabilizer bar bracket to the suspension arm No.2.

Tightening Torque: 1.0 - 1.6 kg-m (7.2 - 11.6 ft-lb)

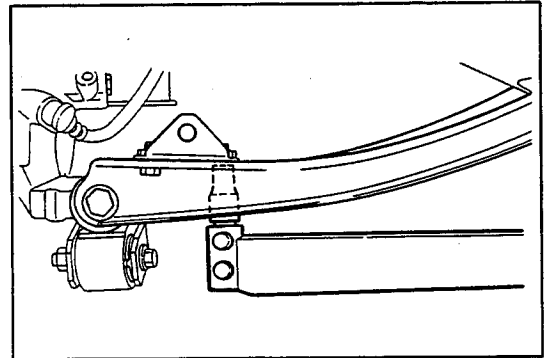

Fig. 6-88

WR-06089

- (2) Tighten the stabilizer link to the rear stabilizer bar bracket temporarily with the bolts and nuts.

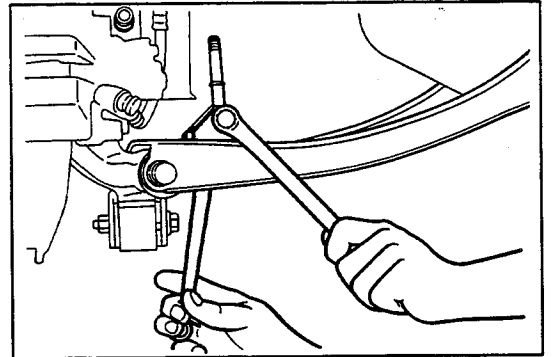

Fig. 6-89

WR-06090

- (3) Fit temporarily the bush, bracket and stabilizer bar to the body.

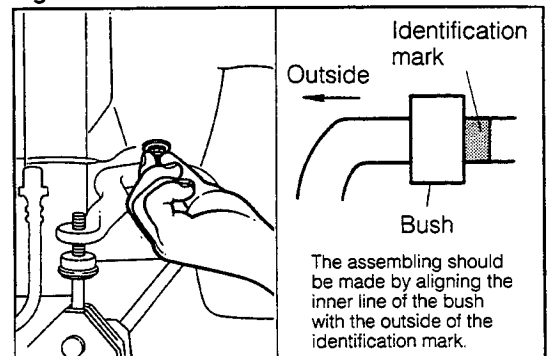

Fig. 6-90

WR-06091

- (4) Fit the stabilizer bar to the stabilizer link. Tighten the nuts temporarily.

NOTE:

Assemble the bush and bracket, as shown in the right figure.

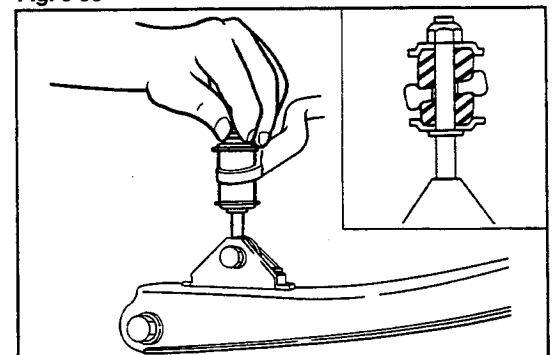

Fig. 6-91

WR-06092

2. Tightening of bolts and nuts

- (1) Tighten the nuts attaching the stabilizer bar to the stabilizer link.

Tightening Torque: 1.0 - 1.6 kg-m (7.2 - 11.6 ft-lb)

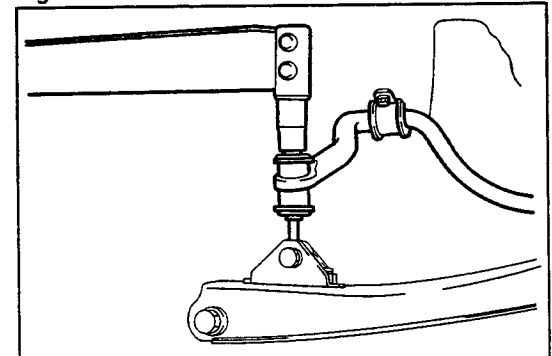

Fig. 6-92

WR-06093

REAR AXLE & SUSPENSION

- (2) Tighten the stabilizer bar attaching bolts at the body side.
Tightening Torque: 1.0 - 1.6 kg-m (7.2 - 11.6 ft-lb)

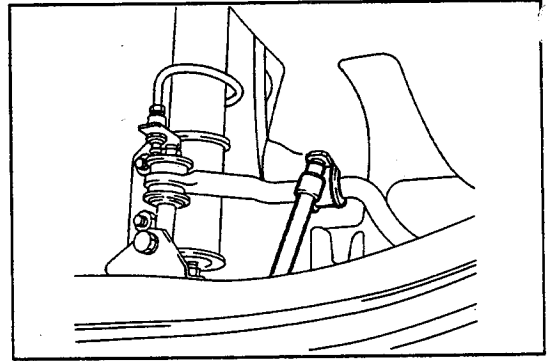

Fig. 6-93

WR-06094

- (3) Tighten the attaching bolts and nuts of the stabilizer link.
Tightening Torque: 1.9 - 3.1 kg-m (14 - 22 ft-lb)

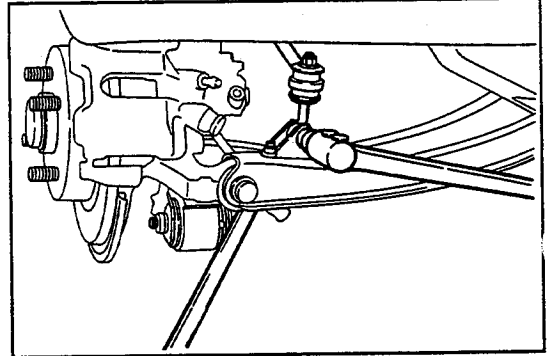

Fig. 6-94

WR-06095