

ENGINE MECHANICALS

6. Checking of crankshaft balance shaft drive gear

(1) Check the crankshaft balance shaft drive gear for damage or wear. Replace it, as required.

WM-05333

(2) Remove the crankshaft balance shaft drive gear from the crankshaft, using the following SST.

SST: 09253-87202-000

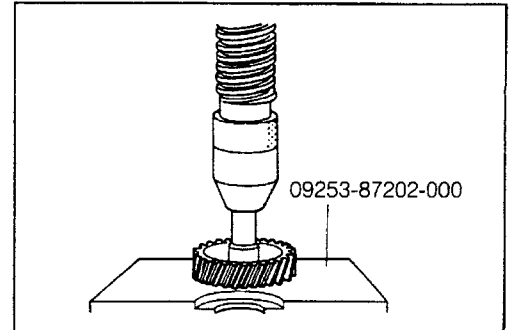

Fig. 5-281

WM-05334

(3) Install the crankshaft balance shaft drive gear to the crankshaft, using the following SST's.

SST: 09506-87303-000

09253-87202-000

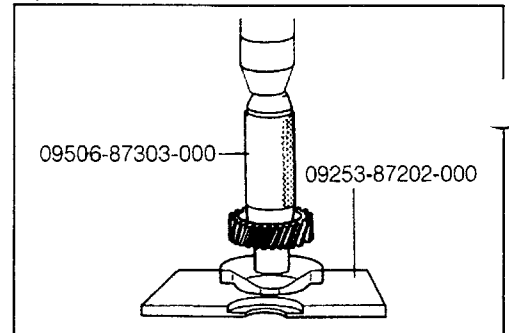

Fig. 5-282

WM-05335

NOTE:

Make sure that the key groove at the crankshaft side and the woodruff key exhibit no damage. The assembling should be made by aligning the woodruff key at the crankshaft with the key groove of the crankshaft balance shaft drive gear.

7. Checking of flywheel

(1) Checking flywheel for runout

① Tighten the flywheel to the specified torque.

Tightening Torque

kg-m (ft-lb)

CB-23 & CB-61 engines	4.0 - 5.0 (29 - 36)
CB-80 engine	6.0 - 7.0 (43 - 51)

NOTE:

Prior to the check, be sure that the crankshaft bearings have been tightened to the specified torque.

② Check the flywheel for runout with a dial gauge.

Runout limit of flywheel: 0.1 mm (0.0039 inch)

If the measured runout exceeds the limit, replace the flywheel.

(2) Ensure that the ring gear and clutch disc contact surface exhibit no wear or damage.

WM-05336

8. Checking of other parts

(1) Check the other parts for damage or cracks, etc. Replace the parts, as required.

(2) As for the oil pump check, see the section under "Unit Inspection" (page 7-3 to 7-5).

(3) As for the water pump check, see the section under "Unit Inspection".

WM-05337

INSTALLATION

CAUTION

1. Clean all parts thoroughly.
2. Apply new engine oil to the sliding and rotating parts before assembling.
3. Replace all gaskets and "O" rings.
4. Use liquid packing as required to prevent water leakage and oil leakage.
5. Use the proper attaching bolts, nuts and washers. Tighten the nuts and bolts to the specified torque. Be very careful not to overtighten the studs installed to aluminum alloy parts.
6. When marks have been put during the disassembly, perform the reassembly in accordance with these marks. Confirm that the pistons and other parts are assembled correctly, meeting the specified clearance.

WM-05338

1. Install the cylinder block to the following SSTs.

SSTs: 09219-87202-000
09219-87701-000

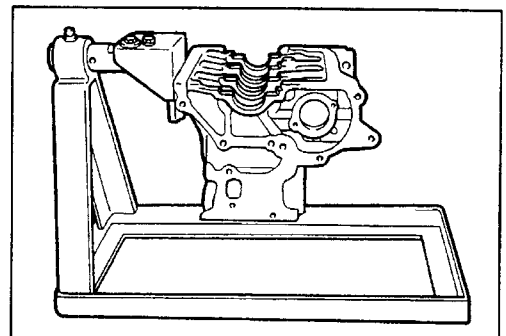

Fig. 5-283

WM-05339

2. Installation of crankshaft upper bearings

(1) Install the crankshaft upper bearings to the bearing sections of the cylinder block. Do not touch the front surface or back surface of the bearing and also the bearing installation surfaces of the cylinder block during the installation.

(2) Apply engine oil to the surfaces of the installed bearings.

NOTE:

Wipe off any oil on the back surface of each crankshaft bearing.

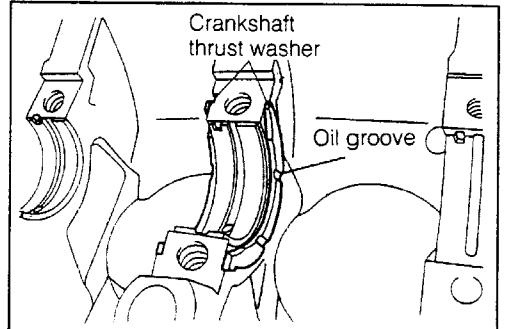

Fig. 5-284

WM-05340

3. Assembly of crankshaft

Apply engine oil to the crankshaft main bearing journals. Then, assemble the crankshaft in the cylinder block.

NOTE:

Be very careful not to scratch each of the crankshaft journals during the assembly.

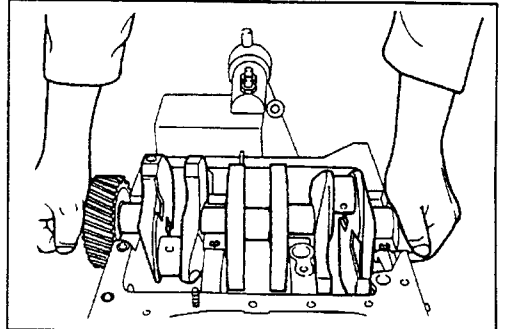

Fig. 5-285

WM-05341

ENGINE MECHANICALS

4. Assembly of thrust washers

Apply engine oil to the thrust washers. With the side having the oil groove facing toward the crankshaft, insert each washer between the cylinder block and the crankshaft.

NOTE:

The insertion position is the crankshaft main bearing journal No.3 at the upper side.

WM-05342

5. Installation of crankshaft lower bearings and crankshaft bearing caps

(1) Assemble the crankshaft lower bearing to each crankshaft bearing cap.

(2) Liberally apply engine oil to each bearing surface. Then, install the bearing caps in the cylinder block.

NOTE:

- ① Be careful not to scratch each journal of the crankshaft.
- ② Install the bearing caps in such a way that the arrow mark provided on each bearing cap faces toward the front side of the engine.

(3) Tighten the crankshaft bearing caps to the specified torque in the sequence indicated in the right figure.

NOTE:

- ① After the bearing caps have been tightened temporarily, make sure that the crankshaft can be turned lightly. Then, each time the bearing cap is further tightened, make sure that the crankshaft still can be turned lightly.
- ② On Type CB-80 engine, the bracket oil nozzle No.1 and No.2 are tightened in common at the bearing caps No.1 and No.3.

Temporal Tightening Torque

kg-m (ft-lb)

CB-23 & CB-61 engines	2.5 - 3.5 (18 - 25)
CB-80 engine	5.0 - 5.5 (36 - 40)

Final Tightening Torque

kg-m (ft-lb)

CB-23 & CB-61 engines	5.4 - 6.6 (39 - 48)
CB-80 engine	6.4 - 7.6 (46 - 55)

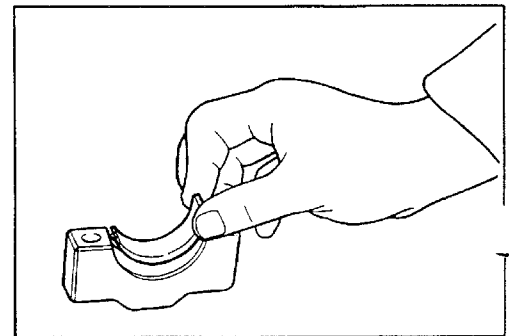

Fig. 5-286

WM-05343

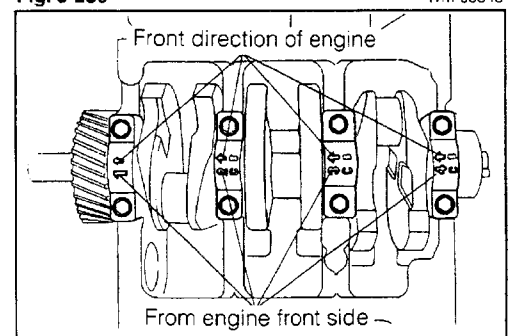

Fig. 5-287

WM-05344

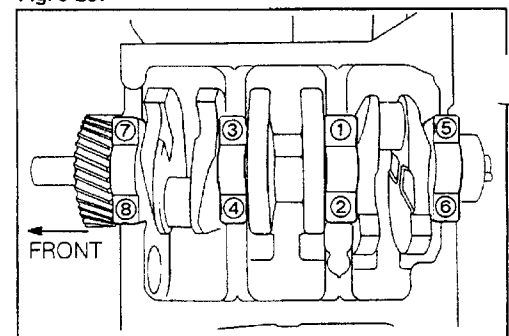

Fig. 5-288

WM-05345

- 6. Install the balance shaft rear cover gasket.

NOTE:

The gasket is a nonreusable part.

- 7. Install the balance shaft rear cover.

WM-05346

- 8. Install the oil seal retainer gasket.

NOTE:

The gasket is a nonreusable part.

- 9. Installation of oil seal retainer with oil seal
 - (1) Drive a new oil seal into position, using the following SST.
 - SST: 09515-87301-000

- (2) Apply engine oil to the rear oil seal contact section of the crankshaft and the lip section of the oil seal. Then, install the oil seal retainer in the cylinder block.

- 10. Install the rear end plate.

- 11. Installation of flywheel

- (1) Attach the flywheel to the crankshaft rear end.
- (2) Tighten the bolts evenly over about two stages in the sequence indicated in the right figure.

Tightening Torque

kg-m (ft-lb)

CB-23 & CB-61 engines	4.0 - 5.0 (29 - 36)
CB-80 engine	6.0 - 7.0 (43 - 51)

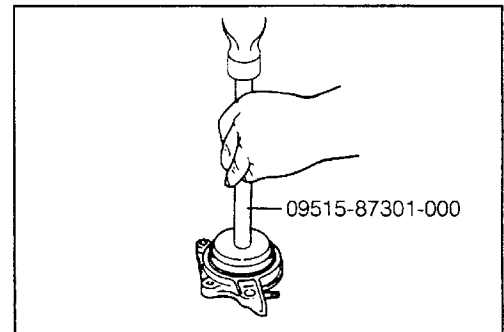

Fig. 5-289

WM-05347

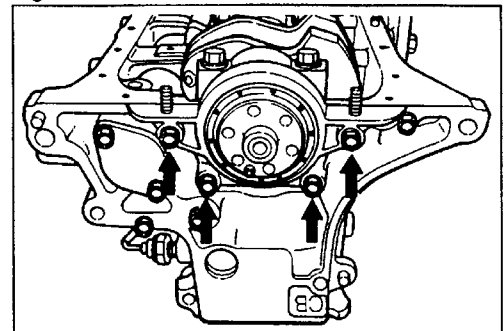

Fig. 5-290

WM-05348

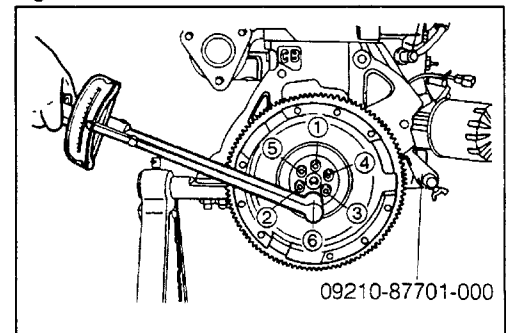

Fig. 5-291

WM-05349

ENGINE MECHANICALS

12. Assembly of connecting rod with lower bearing and piston

(1) Assemble the connecting rod and piston, using the following SST.

SST: 09221-25018-000

WM-05350

- ① Insert the spring into the main body.
- ② Insert the larger bar into the main body.
- ③ Install the fitting piece to the main body, with the side having a cut-out section facing upward.
- ④ Install the piston on the main body, aligning with the cut-out section of the fitting piece.

NOTE:

Apply engine oil to the piston pin hole.

- ⑤ Insert the piston pin into the piston pin hole.

NOTE:

Apply engine oil to the piston pin.

- ⑥ Insert the smaller bar into the piston pin.
- ⑦ Insert the small end of the connecting rod into the piston pin hole.

NOTE:

Align the front mark of the piston with the front mark of the connecting rod.

- ⑧ Press the piston pin by pressing the smaller bar mounted on the piston pin.

(2) Assembling oil ring in piston

- ① Fit the expander spacer to the oil ring groove.

NOTE:

Install the expander spacer in such a way that spacer ends may not coincide with the front mark.

② Assemble the upper rail.

NOTE:

- Be careful not to scratch the piston by the end of the rail.
- Set the rail in such a way that the ends of the rail are deviated to the left 90 degrees from that of the expander spacer.

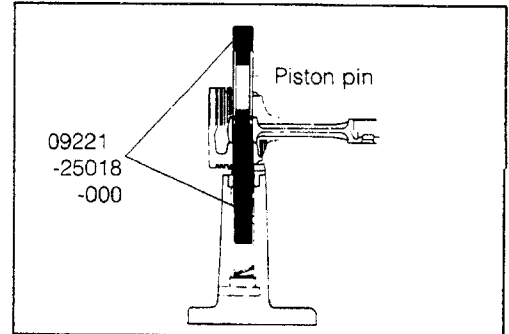

Fig. 5-292

WM-05351

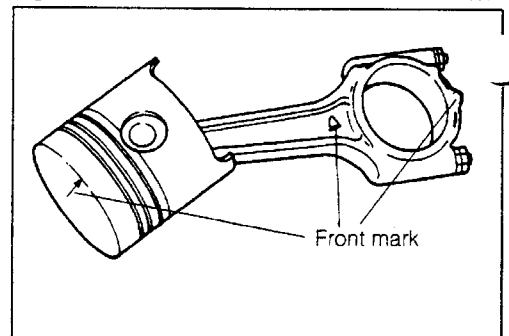

Fig. 5-293

WM-05352

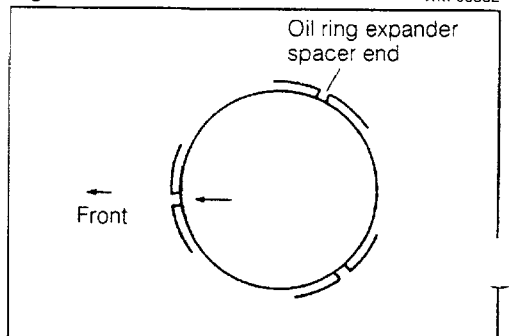

Fig. 5-294

WM-05353

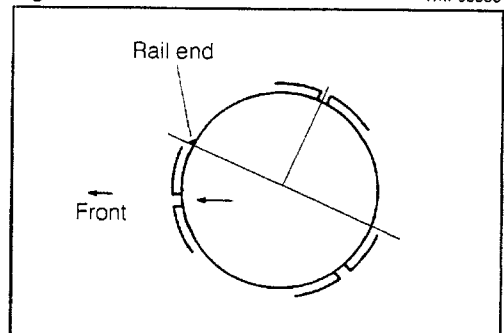

Fig. 5-295

WM-05354

- ③ Assemble the lower rail.

NOTE:

- Utmost care must be exercised not to scratch the piston by the end of the rail.
- Set the rail in such a way that the ends of the rail are deviated to the right 90 degrees from that of the expander spacer.

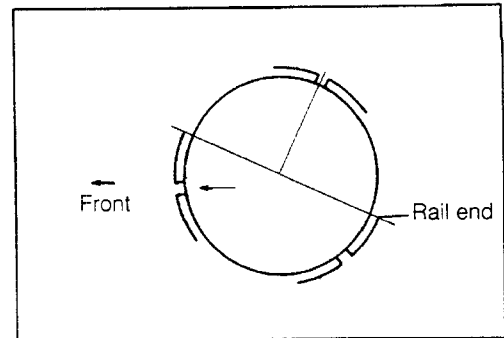

Fig. 5-296

WM-05355

- (3) Assemble the compression rings No.1 and No.2 in such a way that each end of the compression rings is 120 degrees apart from the end of the expander spacer of the oil ring in opposite directions from each other. In this way, make sure that no ends come in the same angle on the circumference of the piston.

NOTE:

Utmost care must be exercised not to scratch the piston by the end of the ring.

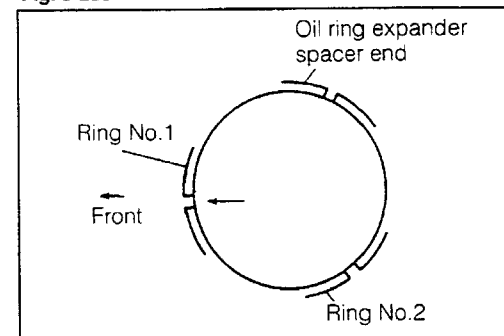

Fig. 5-297

WM-05356

- (4) Install the connecting rod upper bearing. Do not touch the upper bearing installation surface of the connecting rod and also the front surface or the back surface of the upper bearing during the installation.

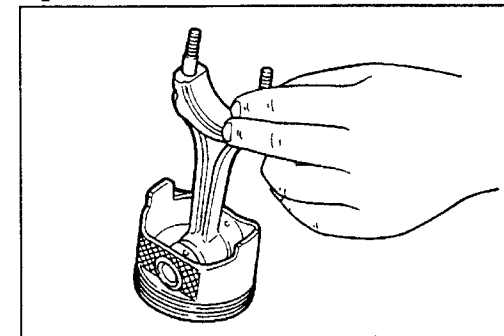

Fig. 5-298

WM-05357

- (5) Apply engine oil to the side wall of the piston, piston rings and piston pin.

NOTE:

Make sure that the ends of each ring does not move during this operation.

- (6) Apply engine oil to the cylinder wall, surface of the connecting rod upper bearing and crankpin journal.

WM-05358

- (7) Compress the piston rings, using a piston ring compressor. Then, assemble the piston into the cylinder bore.

SST: 09217-87701-000

NOTE:

- ① Be sure to install the piston in the correct direction, referring to the position of the front mark.
- ② Make sure that the ends of each ring does not move during the installation.
- ③ Care must be exercised to ensure that the crankshaft journal is not scratched by the connecting rod.

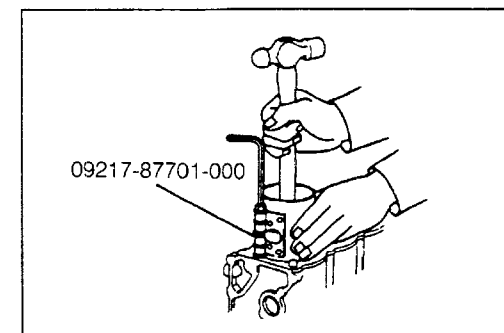

Fig. 5-299

WM-05359

ENGINE MECHANICALS

13. Assembling connecting rod bearing cap with lower bearing

(1) Install the connecting rod lower bearing to the connecting rod bearing cap. Do not touch the lower bearing installation surface of the connecting rod bearing cap and also the front surface or the back surface of the lower bearing during the assembly.

(2) Apply engine oil to the bearing surface.
 (3) Install the connecting rod bearing cap, with the front mark facing toward the front side of the engine.

Tightening Torque

kg-m (ft-lb)

CB-23 & CB-61 engines	2.1 - 2.9 (15 - 21)
CB-80 engine	4.2 - 5.2 (30 - 38)

NOTE:

① When tightening the connecting rod bearing cap, use the following SST to prevent the crankshaft from turning.

SST: 09210-87701-000

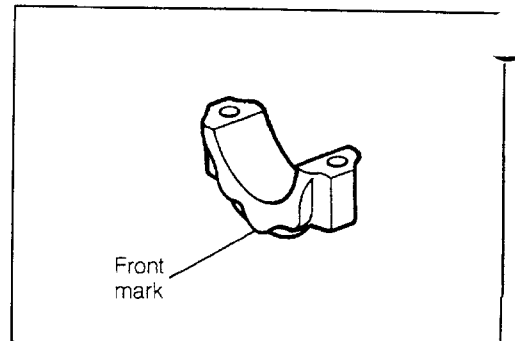

Fig. 5-300

WM-05360

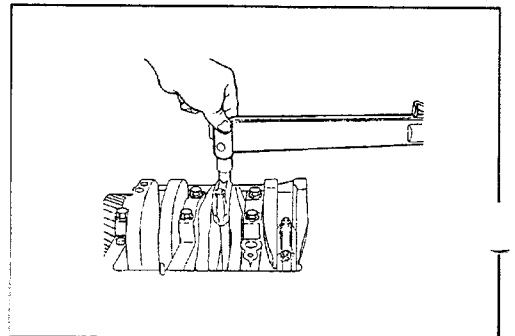

Fig. 5-301

WM-05361

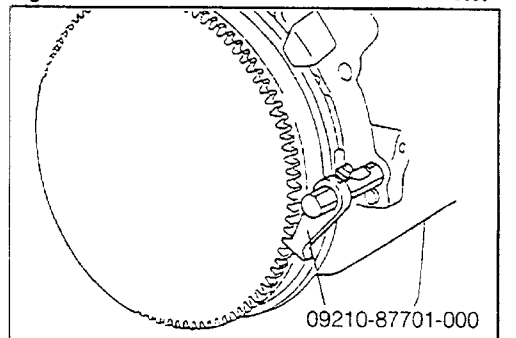

Fig. 5-302

WM-05362

14. Assembling Balance Shaft

(1) Apply engine oil to the balance shaft bearing of the cylinder block.

(2) Apply engine oil to the balance shaft bearing journals and thrust washer sections.

WM-05363

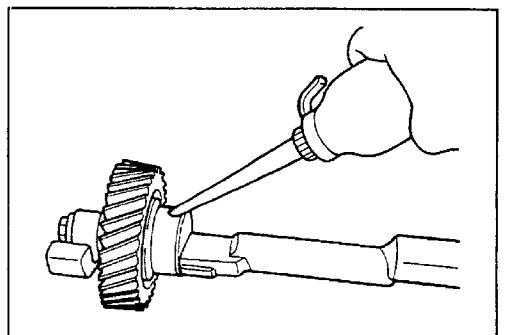

Fig. 5-303

WM-05364